



# Bodleian Libraries

UNIVERSITY OF OXFORD

This book is part of the collection held by the Bodleian Libraries and scanned by Google, Inc. for the Google Books Library Project.

For more information see:

<http://www.bodleian.ox.ac.uk/dbooks>



This work is licensed under a Creative Commons Attribution-NonCommercial-ShareAlike 2.0 UK: England & Wales (CC BY-NC-SA 2.0) licence.

THE  
PRACTICAL SURVEYOR:  
A  
TREATISE UPON SURVEYING.

---

THOMAS HOLLOWAY.

**GEORGE CORDING,  
WATERPROOFER.**

---

**VENTILATED HUNTING COAT,**

**LEGGINGS, AND VALISE.**

**VENTILATED SHOOTING COAT.**

**KNEE AND ANKLE BOOTS.**

**FISHING STOCKINGS & BROGUES**

**DRIVING COATS AND APRONS.**

---

**GEORGE CORDING,  
125, REGENT STREET, W.,  
231. STRAND W.C.**





**CITY END OF OXFORD STREET.**

**HENRY HEATH.**

Note Address, "CITY END," as a renumbering is contemplated by the Board of Works.



**COMFORTABLE SILK HATS,**  
With Elastic Felt Brim, 17s.

These Hats have exactly the usual appearance and strength, but fit with the comfort of a Soft Felt. Recommended for Riding, Driving, and to gentlemen who wear their Hats for hours at a time. No pressure on the forehead. No headaches.

"ROUGH WEATHER" HATS, 10s. 6d.



**BEST FELT HATS.**

The New "Vicuna" Brown, and all colours,  
7s. 6d., 9s. 6d., 10s. 6d.

The "Sans Souci" Hat, 8s. 6d., post free,  
Beautifully soft and light for travelling or evening wear, will fold to go in the pocket.

**HENRY HEATH, Hat Manufacturer,**  
393 (CITY END), OXFORD STREET, LONDON, W.  
ESTABLISHED 60 YEARS. (OVER AGAINST NEWMAN STREET.)

To RESIDENTS in the COUNTRY.

**HENRY HEATH'S**

**PATENT HEAD-MEASURING BAND,**

For taking the FORM and SIZE of the head. The Band is forwarded post free to country residents for "Self-measurement," ensuring a comfortable fitting hat; with Book of Shapes.

**EXTRA QUALITY, SILK HATS,**

Cash price, 17s.

Henry Heath's successful system of Head-Measurement ensures the luxury of a well-fitting Hat, adapted to the form of the wearer's head.

**THE NARROW HAT BRUSH, 1s.**

A capital brush for keeping hats free from dust and spots.

By post, one stamp extra.

**THE "DUPLEX" HAT BRUSH,**

Hard Bristles one side, soft Hair the other.

Price 1s. 6d.; post free, 19 stamps.

"The most useful and handy Brush ever introduced."

**COUP DE FER POUR CHAPEAU.**

A small handy gas-iron.

Price 1s.: post free, 16 stamps.

**THE "VELOUR" HAT POLISHER.**

For giving glossy finish to a Hat; as used in Henry Heath's manufactory.

Post free, seven stamps.

Books of shapes and prices forwarded post free on application.

Henry Heath, manufacturing his own Goods, can guarantee—1st, their Quality; 2nd, Excellence of Finish; 3rd, Style. His Factory (adjoining) employs upwards of Seventy Persons. His goods are charged Cash Prices, and will compare favourably with any Store Goods. His customers can always rely upon receiving business-like attention.



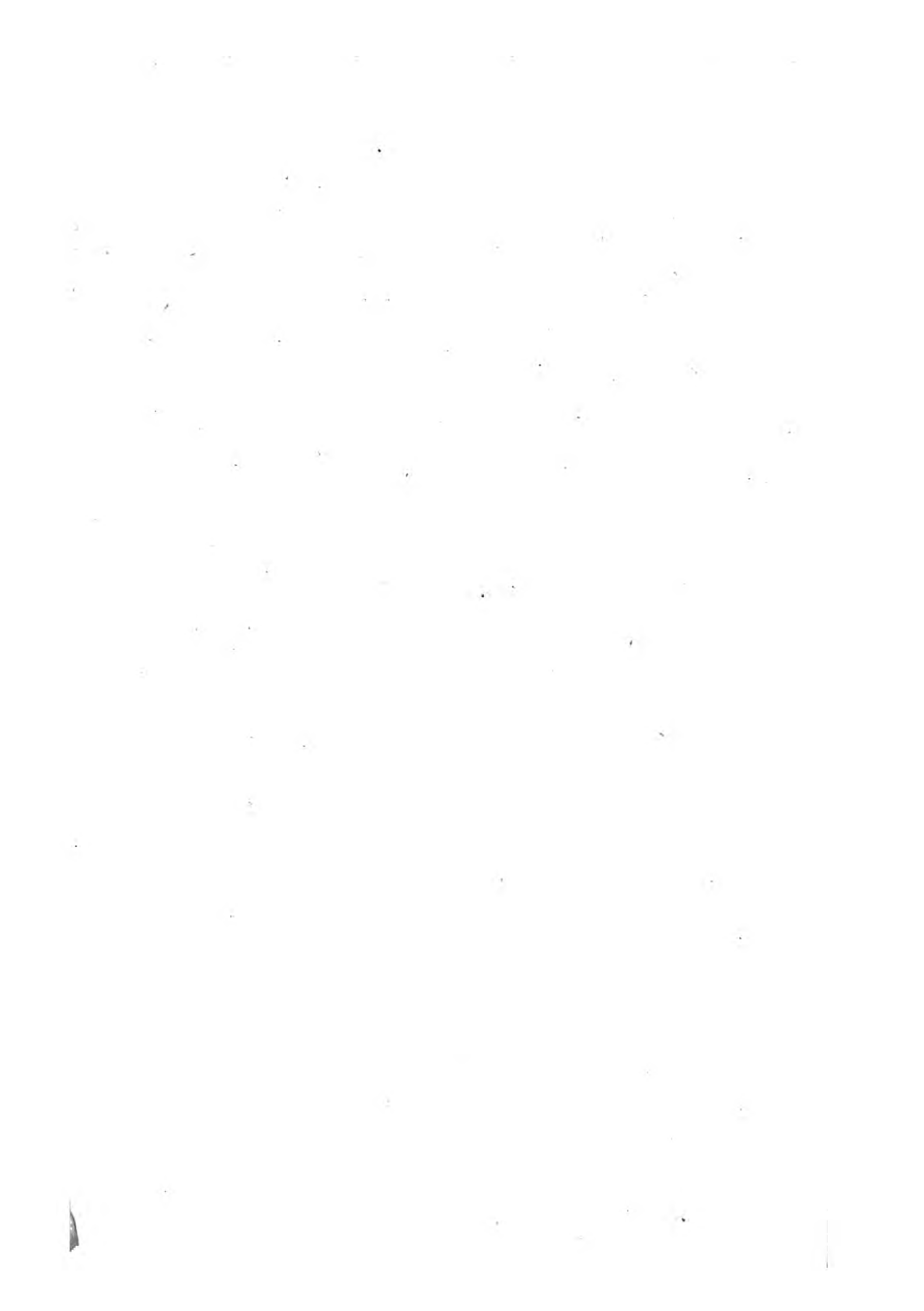

THE  
**PRACTICAL SURVEYOR.**

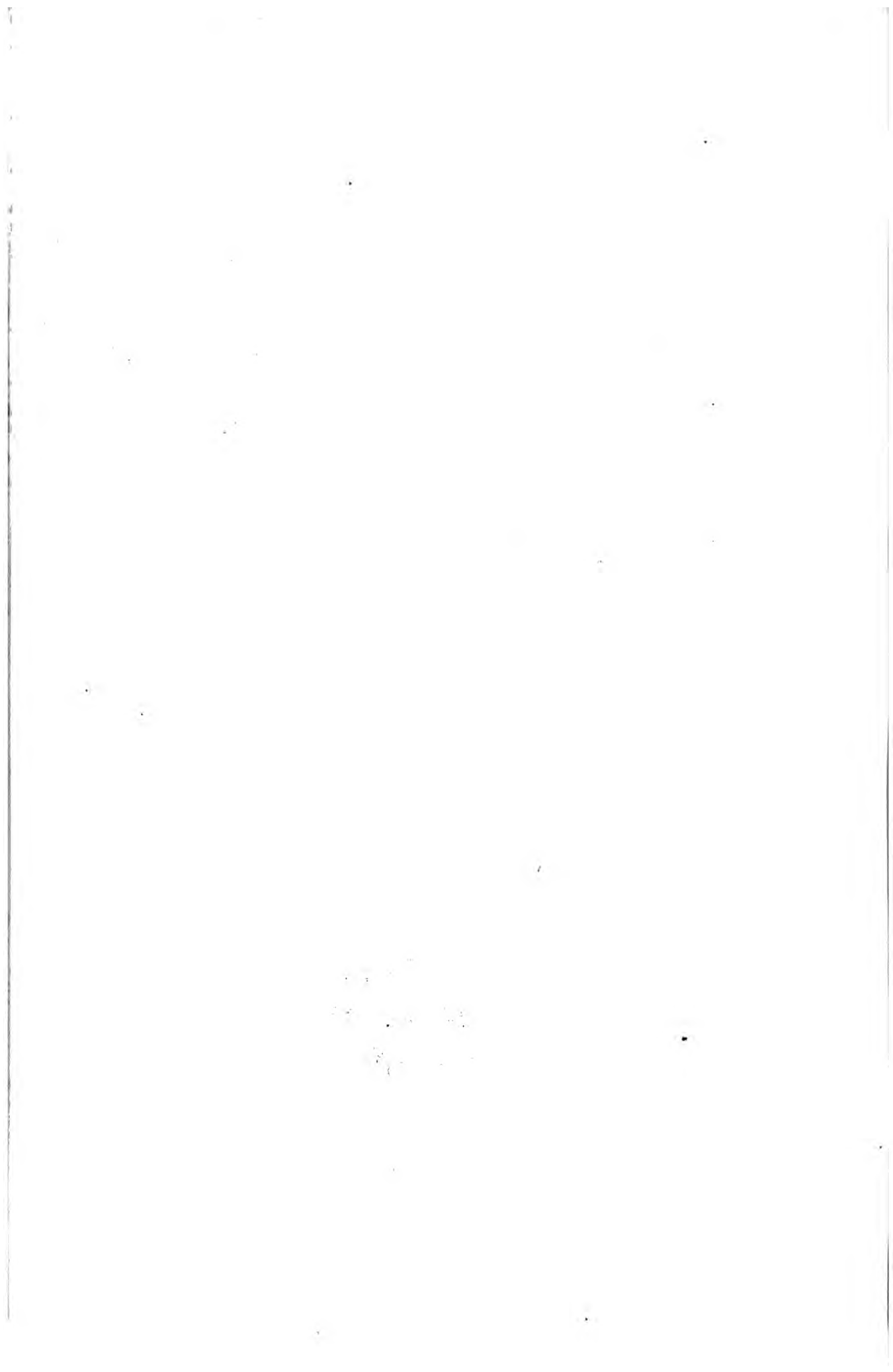



THE  
PRACTICAL SURVEYOR:

A  
TREATISE UPON SURVEYING.

SPECIALLY ARRANGED FOR THE GUIDANCE OF PUPILS,  
STEWARDS, THE SCHOLASTIC PROFESSION,  
AND INTENDING EMIGRANTS.

BY  
THOMAS HOLLOWAY.



HORACE COX,  
"THE FIELD" OFFICE, 346, STRAND, W.C.

1881.

183. e. 60.

LONDON :  
PRINTED BY HORACE COX, 346, STRAND, W.C.

TO  
SIR GABRIEL GOLDNEY, BART., M.P.,

OF  
BEECHFIELD, CORSHAM, WILTS,

THIS TREATISE IS MOST RESPECTFULLY DEDICATED  
BY HIS MUCH OBLIGED AND VERY OBEDIENT  
SERVANT

THOMAS HOLLOWAY.



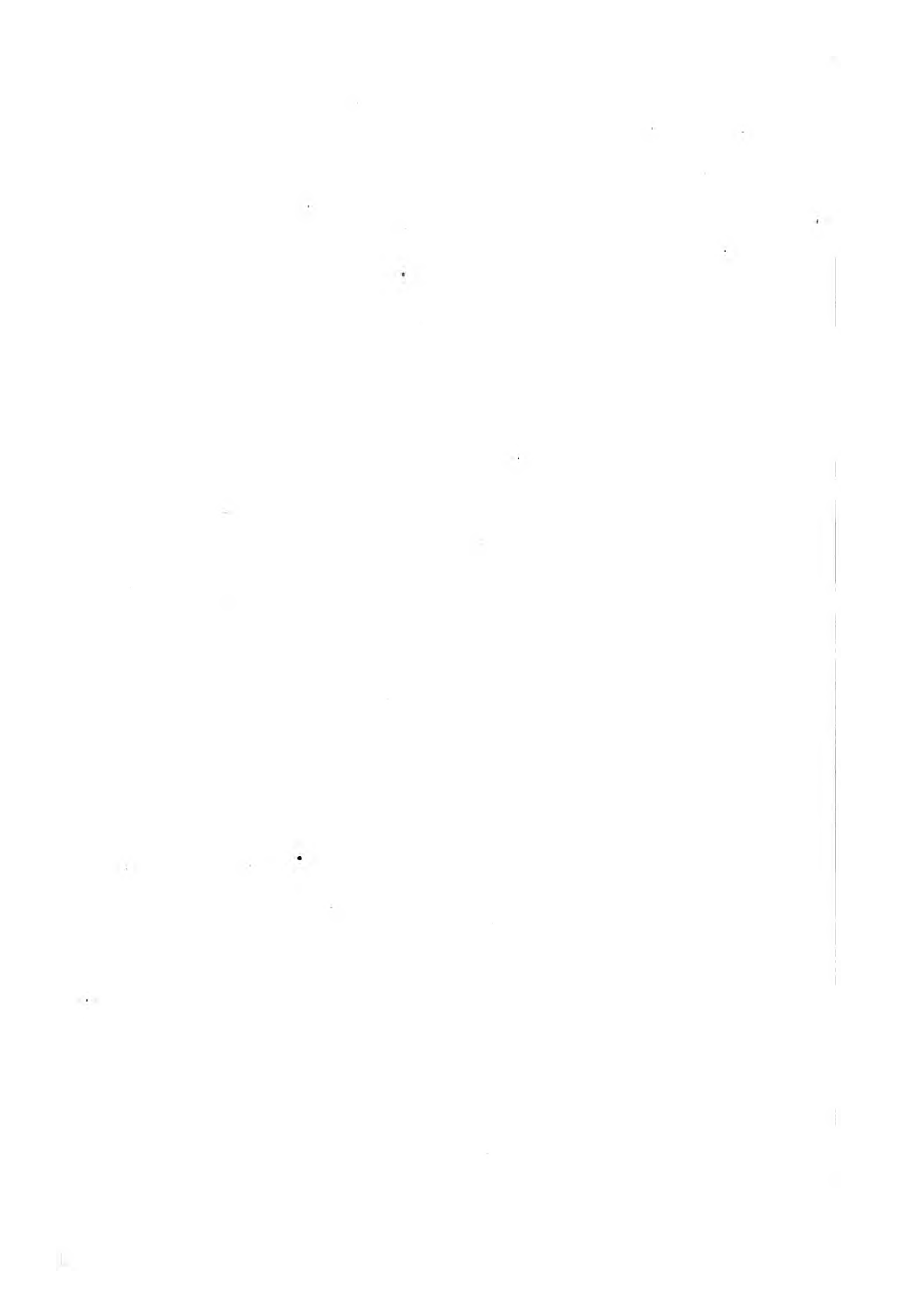

## PREFACE.

---

IN launching this little treatise into the world I feel bound, with a consciousness of many shortcomings, to ask for forbearance, and generosity.

I commenced and have continued my labours at the request of many friends, who have repeatedly assured me they had sought in vain for a practical work on the subject of surveying devoid alike of abstruse algebraical or trigonometrical calculations.

A work of this kind, I am persuaded, is of as much value now as it would have been in the old Railway and Tithe commutation days. I feel confident it will be found useful to those seeking employment abroad, also to land agents, stewards, and the scholastic profession; and I trust that in some parts it may recommend itself to others.

Excepting transcription from other works on simple stereotyped and indispensable matters, handed down from many generations, these pages are the issue of twenty-two

years' experience, in the first place as assistant to some of our country's best surveyors, and latterly on my own account.

Acting precisely upon the following recommendations, I have had the honour of making many surveys which have passed the Inclosure Commissioners for England, and Wales as "first class."

T. HOLLOWAY.

Chippenham, Wilts. ;  
*September, 1880.*

---



# CONTENTS.

---

## CHAPTER I.

THE MAN AND HIS OUTFIT.....	<i>page</i>	1
-----------------------------	-------------	---

## CHAPTER II.

THE CHAIN—CAUTIONS TO BEGINNERS—BEST FIGURE FOR CHAIN SURVEYING.....		4
-------------------------------------------------------------------------	--	---

## CHAPTER III.

BOUNDARIES .....		8
------------------	--	---

## CHAPTER IV.

SETTING OUT LINES BY THE EYE AND PASSING OBSTRUC- TIONS .....		10
------------------------------------------------------------------	--	----

## CHAPTER V.

DIVISION OF THE CIRCLE AND USE OF BOX SEXTANT— CHAIN ANGLES CONDEMNED—CROSS STAFF CON- DEMNED — THE OPTICAL SQUARE — MEASURING INACCESSIBLE DISTANCES .....		16
----------------------------------------------------------------------------------------------------------------------------------------------------------------------	--	----

## CHAPTER VI.

THE THEODOLITE — SETTING OUT LINES WITH THE THEODOLITE .....		20
-----------------------------------------------------------------	--	----

CONTENTS.

---

CHAPTER VII.

REDUCTION OF THE MEASURE OF UNDULATING GROUND  
TO HORIZONTAL MEASURE AND TABLE OF VERTICAL  
ANGLES .....page 22

CHAPTER VIII.

MEASURING LINES—THE OFFSET STAFF, AND TAKING  
OFFSETS..... 27

CHAPTER IX.

TO PROVE THE CORRECTNESS OF OBSERVATIONS TAKEN  
WITH THE SEXTANT—SINGLE FIELDS MEASURED  
WITH THE CHAIN AND OPTICAL SQUARE, SO THAT  
THE AREAS CAN BE DIRECTLY CALCULATED ..... 29

CHAPTER X.

TO SET OUT A RIGHT ANGLE WITH THE CHAIN—  
FIGURES OF THE LINES OF MEASUREMENT BEST  
ADAPTED TO IRREGULAR FIELDS ..... 34

CHAPTER XI.

EQUALISING BOUNDARIES, AND DRAWING A TRIANGLE  
EQUAL TO A GIVEN FIGURE ..... 38

CHAPTER XII.

COMPUTATION OF AREAS OF IRREGULAR FIELDS ..... 40

CHAPTER XIII.

EXAMPLE OF A SURVEY OF SEVERAL FIELDS TOGETHER,  
AND THE FIELD BOOK ..... 43

## CHAPTER XIV.

REFERENCE NUMBERS TO MAPS—TO PUT DETACHED BUILDINGS IN CORRECT POSITIONS ON A PLAN BY MEANS OF UNMEASURED LINES—LINES MEASURED ON THE WORK—MAKING STATIONS .....	page 47
---------------------------------------------------------------------------------------------------------------------------------------------------------------------------	---------

## CHAPTER XV.

PLOTTING—SELECTION AND MANAGEMENT OF PAPER— INKING IN .....	53
----------------------------------------------------------------	----

## CHAPTER XVI.

SURVEYS MADE FOR THE PURPOSE OF DIVIDING LAND INTO STATED QUANTITIES.....	57
------------------------------------------------------------------------------	----

## CHAPTER XVII.

SETTING OUT ALLOTMENTS AND BUILDING PLOTS .....	60
-------------------------------------------------	----

## CHAPTER XVIII.

ANGLES AND BEARINGS, AND USE AND ADJUSTMENT OF CIRCULAR PROTRACTOR.....	64
----------------------------------------------------------------------------	----

## CHAPTER XIX.

TRAVERSE SURVEYS .....	70
------------------------	----

## CHAPTER XX.

TRESPASS .....	73
----------------	----

## CHAPTER XXI.

QUALITY LINES — SUPERSTRUCTURES AND WORKS UNDERGROUND—HARVEST AND COPPICE WORK— REDUCING PLANS FROM A LARGE SCALE TO A SMALL ONE .....	75
-------------------------------------------------------------------------------------------------------------------------------------------------	----

## CHAPTER XXII.

TO COPY A MAP—COLOURING, PENMANSHIP, &c.... *page* 82

## CHAPTER XXIII.

COMMENCEMENT OF A PARISH SURVEY—SURVEYING TO  
A SCALE OF FEET ..... 86

## CHAPTER XXIV.

TOWN SURVEYING..... 88

## CHAPTER XXV.

TESTING THE ACCURACY OF A SURVEY—GENERAL  
REMARKS ..... 94

## CHAPTER XXVI.

IN MEMORY OF THE PAST ..... 97

---

# THE PRACTICAL SURVEYOR.

---

## CHAPTER I.

### THE MAN AND HIS OUTFIT.

THE practice of land surveying consists in taking such measurements, both angular and lineal, as will enable a person to delineate accurately on a map or plan, according to a truly horizontal scale, the several boundaries of fields, lands, gardens, rivers, ponds, woods, roads, houses, buildings, and the like, together with anything that may be upon the surface of the ground within such boundaries. It further embodies the computation of the area of the property so surveyed.

The principal essentials for a surveyor are, first, a good sound and hardy constitution—for a man who cannot walk twenty miles per day regularly in almost any weather or temperature, will never make a good and rapid surveyor; secondly, a suitable outfit in the way of clothes, boots, &c.; and thirdly, a supply of accurate and well-made field and office instruments. I will first treat of what I consider the best outfit for a really practical surveyor engaged upon a survey some distance from home. The clothes should be of a close tough cloth, so that in going through hedges, underwood, briars, furze, and similar objects of a prickly nature, the body shall be well pro-

tected. The coat should be of the old-fashioned shooting coat pattern with large inside or hare pockets ; the trousers should fit loosely on the body, and closely below the knee. It is the custom of many surveyors to wear breeches and gaiters, but I have found from experience that they keep the calf of the leg too warm, and consequently produce a kind of lazy feeling before a man is actually tired : I therefore strongly recommend trousers on that account. Socks will be found preferable to stockings, because the latter require garters, which tend to prevent a proper circulation of the blood and produce varicose veins. The boots should be of porpoise hide, well made, of good fit, free from any cloth or soft lining—which is sure to pucker in case of wet and produce sore feet—broad at the tread and toes, and stout in the sole. The laced boot will be found the best, and I would here advise the surveyor to be particular to have eyelet holes instead of the now fashionable hooks, as the latter cut the bottoms of the trousers to pieces, and, by catching hold of stray brambles, &c., often cause the wearer “to measure his length” on the ground. A light mackintosh and leggings should be taken out, and, if the weather be uncertain, should always be carried in a sling at the back of either the surveyor or his chainman. The clothes to be taken from home should never be less than two entire changes, and three pairs of boots are always necessary to ensure starting out in the morning with a dry pair. It might be an advantage to take a box of waterproof dressing for the boots.

I will not here enumerate the field and office instruments, as every instrument hereafter named will be required.

It may not be out of place to mention that, as the duties of a surveyor are highly important duties, par-

---

ticularly when he is dealing with property of great value, the utmost care, nicety, and precision are indispensable. Let me once for all caution the surveyor to first well consider his scheme, and then carry it out in a painstaking manner. Difficulties, I am bound to admit, often occur, but they can all be overcome by thought and steady continuous perseverance.

It is a good thing to have a kind of official roll call, enumerating the things to be taken out on a survey. I once recollect a surveyor and his two pupils proceeding five miles from home, and afterwards discovering they had forgotten the chain!



## CHAPTER II.

### THE CHAIN—CAUTIONS TO BEGINNERS—BEST FIGURE FOR CHAIN SURVEYING.

THE land chain, the invention of the Rev. Edmund Gunter, is the surveyor's most complete and original instrument: not a word too much can be said in its favour.

It contains 100 links, each link measuring 7·92 inches. Its length is therefore 4 rods, or 22 yards, or 66 feet.

A mile is 80 chains in length.

A furlong is 10 chains in length.

A statute acre contains 10 square chains, or 4840 square yards, or 43,560 square feet, or 100,000 square links.

The great feature in the chain is that it is decimally divided to two places: the first place being indicated by pieces of brass attached to it at intervals of ten links; the second being formed by the link itself. For instance, 7 chains and 48 links would be 7·48 chains. This arrangement is alike convenient for entry in the field book, for the computations of areas, and for the conversion of links into yards and feet.

To convert links into yards it is simply necessary to multiply the links by the 22 yards contained in the chain and point off two places of decimals; and to convert links into feet to multiply the links by the 66 feet contained in the chain and point off two places of decimals; thus—

$$50 \text{ links} \times 22 \text{ yards} = 11 \text{ yards.}$$

$$50 \text{ links} \times 66 \text{ feet} = 33 \text{ feet.}$$

To convert yards and feet into links the foregoing operations require reversing.

The first thing to be done by a surveyor is to establish close to his offices a standard chain's length from which to test the length of his chain and tape every morning before using them. I formed my standard on the kerb of a length of straight level paving by marking it with a fine chisel at every ten links. The chain will most likely stretch a little every day it is in use—a new chain is certain to do so—therefore the necessity of a standard measure becomes obvious. If the stretch be only slight—say half an inch—it can be rectified with a hammer by closing every open joint in the rings between the links, or by tapping the ends of several of the straight parts of the links; if, however, the stretch, as is frequently the case, be from one to two inches, it will be necessary to take out some of the rings in such a manner as to keep every division of ten links in its proper place on the standard.

The tape becomes longer or shorter than its stated length in proportion as it is used in wet or dry weather—an old and much-used tape being generally too long. I know of no method of adjusting a tape, and would be much obliged to any surveyor for a practical hint. Where measurements of valuable property in towns have to be given in feet and inches, it becomes necessary for the surveyor to use an accurately divided ten-foot rod, as neither chain nor tape is sufficiently correct. To guard against mischief or tampering, I advise that the surveyor always keep the chain in his own possession. Some years ago, when engaged in surveying an estate in the Forest of Dean, known as the Abbot's Wood, and containing, as nearly as I can recollect, about 800 acres, I had the misfortune to have a link taken out of my chain in the middle of the day.

This occurred through my being incautious enough to leave it outside the door of a public house into which I had gone for refreshment—I should have taken it with me.

These precautionary measures being engraven on the tablet of memory never to be erased, we will proceed to work.

The best figure that it is possible to use in a survey made with the chain alone, and the figure most approved by the Tithe and Inclosure Commissioners, is the triangle, with a tye-line measured from its apex to its base. The nearer the triangle approaches an equilateral triangle the better, because it avoids acute interior angles. The equilateral figure gives you the choice of either side as a base, which it is an advantage to have, as it might, on account of obstructions (of which I shall hereafter treat), be difficult to measure a tye-line from a given apex to a given base, whereas by changing the base the tye-line might be measured easily; it must, however, be borne in mind that the longest side of the triangle should always be the base-line. A practical surveyor will, whenever it is possible for him to do so, always set out his tye-line at a right angle to the base, and thus let it form a perpendicular; this, however, he cannot do until he has acquired the use of an angular instrument.

A trapezium is another admittedly good figure for a survey, but, as it is simply two triangles having one common base, it would be as well to call it two triangles and thus adhere to the one figure.

When the figure to be surveyed is long and not of any great width, as in a railway survey, the base line should run as nearly as is practically convenient through the centre of the work, and the survey be carried out upon

the principle of tye-lines and lines produced through the base as in Fig. 1; but for all field, estate, parish, and

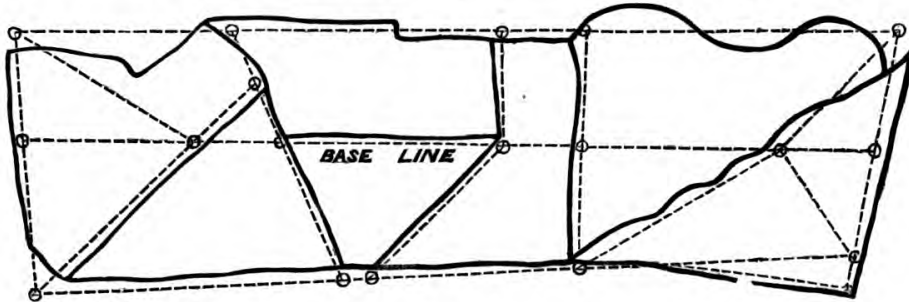

FIG. 1.

inclosure surveys, the figure of the triangle must not be lost sight of.

## CHAPTER III.

### BOUNDARIES.

THE boundary of a field inclosed by a hedge-and-ditch fence is the outer edge of the ditch ; but should the latter not be clearly defined, the boundary must be taken at five links from the stake of the hedge. A dead wood or iron fence must be taken to represent the exact boundary of the property, except in special cases. A wall always has an owner, and care must be taken to find to whom it belongs, or you may take your measurement on the wrong side of it. Generally speaking, the drip of a wall is *from* the property to which it belongs. Common field lands are generally bounded by strips of pasture, or meres, or stones ; meadows, by stones or posts. It will sometimes occur that neither a dead fence nor the edge of the ditch is the actual boundary of the property, many manors claiming a freebord of a certain number of feet beyond the fence ; it is therefore incumbent upon the surveyor to look after such things and make inquiries where the slightest doubt exists. Sometimes the centre of a brook or stream is the boundary, and sometimes the edge of either limits the property. Careful inquiry should always be made as to the exact ownership of the water and fishery rights in rivers.

As a general rule, it may be taken that the fences of all railways and canals belong to the railway and canal companies. Railway companies are often owners of land

considerably without the limits of the live fence of the railway, on account of the original post-and-rail fence being allowed to decay after the maturity of the quick hedge.

It rarely happens that a fence belongs to a road, although, where a road through an uninclosed common is fenced for safety, the fence must be considered to belong to the road.

The boundaries of manors, parishes, tithings, &c., are of a very variable character, and require in every case to be specially pointed out. Inquiry should always be made as to the last perambulation, and the services of the men who actually made the perambulation should, if possible, be obtained. Most rural districts hold at any rate one old man who is certain to be able to afford valuable information.

If an old map of the property exists, it should certainly be obtained, as many doubtful points on the question of boundaries may be settled by it.

Upon one occasion, when the boundary posts of a parish on a large common had long decayed, I obtained information from an old man which enabled me by digging to discover their underground remains.

Of late years, parts of the boundaries of several parishes have been straightened or regulated under the provisions of the Inclosure Acts, and in certain cases questions of disputed boundaries have been determined; the surveyor will therefore obtain much information from an inspection of the inclosure map and award.

Many boundaries, however, are still in dispute, so much so that it is not rare to find property legally described as being in two certain counties or in either one of the two counties. This most frequently occurs where land has been reclaimed,



## CHAPTER IV.

### SETTING OUT LINES BY THE EYE AND PASSING OBSTRUCTIONS.

AT the commencement of this little work, my idea was to treat fully and separately upon surveying with the chain alone, and surveying with the aid of angular instruments: my views, however, are now changed, and I have decided to classify the matter into departments, and to treat separately upon each in its turn. This necessity forced itself upon me, inasmuch as I found it very difficult to clearly recommend that a survey of any extent should be made solely with the chain, and *vice versâ* that the use of an angular instrument was indispensable. My aim is now to show how a survey can be done well.

In setting out any principal line of a survey, it is always well to let it bear upon some distant object, say the summit of a church steeple, the centre of some tall chimney, or any object of a like nature that is visible from many points of view within the area to be surveyed: and it is of great assistance to the surveyor in the office to get as many lines of his survey as he conveniently can to converge towards such distant object. Apart from the assistance gained by following such a system, an error may easily be detected in the work which otherwise it might take considerable time to discover. Having decided upon the direction the line is to take, and taking the distant

object as part of it, set up a ranging pole,\* taking care to have it perfectly upright in the direction of the line; now walk about eighty yards, if the land be tolerably level, and set up another pole in a direct line with the former pole and the object in the distance; again walk about eighty yards, and set up another pole in a right line with the two poles and the distant object; and so proceed until the line be set out to its required length. If the ground be very undulating, you will be compelled to set up the poles at very short distances, and, as in certain parts of the survey the distant object will not be visible, on no account must you set up a pole without having three of those previously set up in view. It will be patent to any ordinary mind that two poles must of necessity be in one line, whilst three would not be so if any accident, interference, or error had taken place. Imagine for a moment that you had descended a valley and lost sight of a considerable part of your line as well as the distant object, and that, in ascending the other side of the valley, the distant object again appeared suddenly to view. What then? Why the next pole set up should, on your taking a sight some yards behind it, cover all the poles set up on your descent into the valley, and likewise be upon the distant object as was the second pole set up.

Now there are many things to impede the surveyor in his course across a country with a direct line, such as hedges, furze, bushes, woods, rivers, &c., &c., and it is to these I am about to refer. As soon as the line comes upon a hedge, the surveyor or his assistant must, with a bill-hook—to be carried in one of the pockets named

---

\* These are about ten links in length, and are generally painted white. *Vide* price list of Mr. W. F. Stanley, London.



in Chapter I.—cut such a gap in it as will make the line clearly visible on the opposite side, and admit of a man passing through it. In like manner must he cut the line through all furze, underwood, and small timber. In thickly wooded and bushy countries, it is often necessary to employ three or four men to clear the lines and fell small trees, and these men should be instructed to clear the line from the ground to the extreme height of anything in a direct line. If the line were only cleared, say, to the height of a man, by trimming the sides of trees in a level plantation, the overhanging tops would block up the view immediately the ground began to rise or fall; hence the necessity of a clear cut from the ground to the daylight above. It will always be found advantageous when opportunity occurs—as it often does—to set out the line with your back to the sun; *i.e.*, where a line runs due east and west, to commence work in the morning at the western end, and the reverse if you begin to set out a line in the later part of the day.

Should the line cross a river, be careful to set up a pole close to its edge on either side, for use in calculating the distance across when the line is measured.

If the line should become obstructed by the body of a tree, or a building, and the ground should not afterwards rise sufficiently to admit of a view over the top of the obstruction, the latter must be passed by means of a parallel, thus :



FIG. 2.

In the above figure, A B is the right line; C the obstruction; *d d* are ranging poles in the right line; *e e*

are ranging poles in the parallel. Now for the *modus operandi*. To accurately pass an obstruction, is one of the most delicate operations a surveyor is called upon to perform. I know nothing requiring such great care and nicety. Should the obstruction be at a considerable distance from the end of the line, never attempt a parallel of a less length than six chains on each side of the obstruction; but, should the end of the line be nearly reached, a much shorter parallel will suffice. We will presume the obstruction C to be a building fifteen links wide, with the line running into its centre. Let us now set out the parallel of the width of ten links. In the first place, see that the three poles *d d d* on the line A C are most correctly set up in the line: this done, set up the poles *e e e* truly parallel to the line A C by measuring with the correctly marked rod the distance from pole to pole at the top and bottom, and from centre to centre. Now produce the parallel line in the direction of the letter B, and reverse the former operation, which will complete the undertaking.

When I undertook the Inclosure Survey of the Avon and Somerley Commons in Hants, under my late uncle Mr. Harry Holloway, of Ringwood, I had a base line about 400 chains in length set out entirely by the eye. Now as there was no distant object upon which to work, I (by my uncle's advice, than whom there were few better surveyors) erected a high larch pole at the commencement and nailed to it a white flag some three or four yards in depth, and about two feet in width. This pole was visible in places along the whole line and at its termination. A pole of this kind judiciously erected is most useful as a convergent point for other lines of the survey.

Differences of opinion, however, always did and always

will exist. Now there are many surveyors who totally ignore the use of ranging-poles, and who set out lines entirely with "light papers."\* My opinion is against "light papers" in the first place, unless a theodolite be used. I should use ranging-poles, and let an assistant in the rear supplant them with "light papers" and bring the former forward for further use. I have known surveyors waste considerable time in cutting hazel sticks for "lights;" I think if they were to consider the value of their time they would find it more profitable to buy two or three bundles of double deal plaster laths; further, they would avoid unnecessary damage to property. It often becomes necessary to set out a line from a given point, A, to a given point, B, when by reason of a hill between the two points neither is visible from the other, as in Fig. 3.

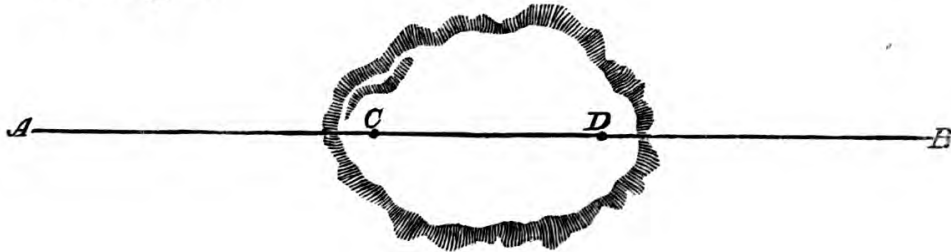

FIG. 3.

In such a case erect the pole, C, at any point on the hill from which A and B are both visible; then, at a convenient distance from C, erect the pole, D, in line with C A. Now if upon returning to C it be found that the poles, C D, are in line with B, the operation will be complete. The probability, however, is that the line, A C D, will not be in line with B. Now, presuming the line, A C D, to bear in the direction of twenty links

\* A piece of paper about four inches square placed in the end of a piece of straight stick about three feet in length.

to the left of B, and the point C to be equidistant from A and B, it only remains for the surveyor to remove C ten links to the left, and produce the line, C A, which will bear correctly on B.

This operation can be much more rapidly performed by two persons, representing C and D, putting each other in line with the points, A and B.

When the hill is of considerable length, and from no point upon it can the points A and B both be seen, the surveyor must, by use of several poles, set out a false line from A, as nearly in the direction of B as he can. He must then ascertain the length of the false line and its deviation at B, from which he will be able to calculate how much any point on the line will require to be moved either to the right or left. For example, the false line measures 20 chains and the deviation at B twenty feet to the left; therefore a pole at one chain from A will require moving one foot to the left, a pole at two chains from A two feet, and so on.

The only real difficulty a surveyor has to contend with in setting out lines is a thick fog.

---

## CHAPTER V.

DIVISION OF THE CIRCLE AND USE OF BOX SEXTANT—CHAIN ANGLES CONDEMNED—CROSS STAFF CONDEMNED—THE OPTICAL SQUARE—MEASURING INACCESSIBLE DISTANCES.

THE circle is divided into 360 degrees, each of which degree is afterwards divided into 60 minutes by means of a vernier. From this division any angle can be taken, the point of the junction of the lines being considered as the centre of the circle.

The box or pocket sextant, is a most useful and accurate angular instrument, particularly upon level ground, and no surveyor should be without one. With it an angle under 100 degrees can be taken to a single minute; angles can be taken with it to 140 degrees, although after passing 100 degrees they gradually become less reliable.

As the use and adjustment of this instrument are so perfectly described in several cheap works upon mathematical instruments, I shall save time by referring to one of them contained in Weale's series. I am bound, however, to say that it is difficult to acquire the use of it from any book, and would always recommend the pupil to have it practically explained by a surveyor. The system of obtaining the angle by means of setting back two lines for a short distance and tying them by measurement (*vide* Fig. 4), cannot be too strongly condemned. Where

tye-lines cannot be measured always use an angular instrument.

Of the instruments used for setting off short lines at right angles nothing for convenience and accuracy can possibly be better than the optical square which, being about the size of a large watch, is constructed upon the same principal as the box sextant. This little instrument, which can be conveniently carried in the vest pocket, is

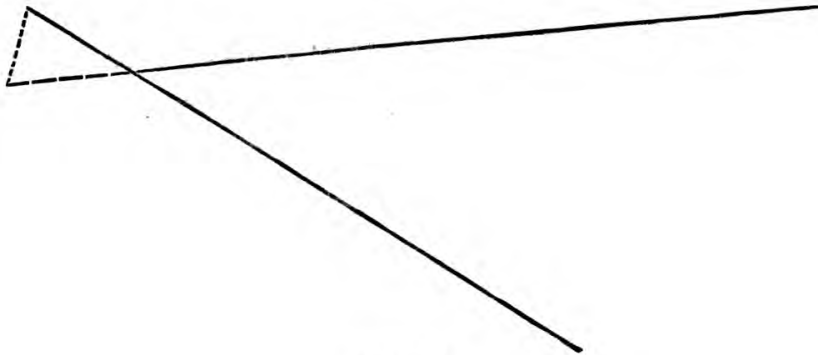

FIG. 4.

permanently set to an angle of 90 degrees, and is specially useful for taking long offsets to buildings, and angular points of fences. I recommend that its practical use and adjustment be explained by a surveyor.

The cross staff has held its own as a surveyor's instrument for many years, but I feel bound to condemn it, as an article of no practical utility—it is questionable if a correct one was ever made.

In Fig. 5 the line A B is measured from A in the direction of B. Upon arrival at E the measurement is interrupted by a river; and before further procedure can be made, it is necessary to calculate the distance from E to C. This can be accomplished with the chain and optical square, thus :

Set out the line E D of any length at right angles to



the line  $A B$  and erect a pole at  $D$ ; set up a pole at  $F$  at any convenient distance from the point  $E$ ; from the point  $F$  set out the line  $F G$  parallel to the line  $E D$  and

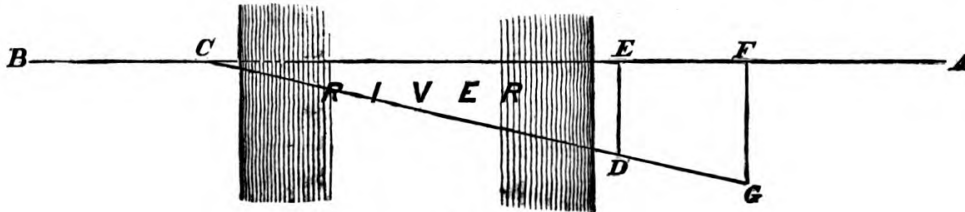

FIG. 5.

erect a pole at  $G$  in line with  $D C$ . Next measure the lengths  $E F$ ,  $F G$ , and  $E D$ , and find the difference in length between  $E D$ , and  $F G$ . Then as the difference between  $E D$  and  $F G$  is to the length  $E F$  so is  $E D$  to  $E C$ .

In Fig. 6  $A B$  is measured as in Fig. 5.  $C D$  is the distance to be calculated with the chain and sextant.

Poles being erected at  $C D$  in the line  $A B$ , set up the poles  $E$  and  $G$  at an angle of 60 degrees from the line  $A B$

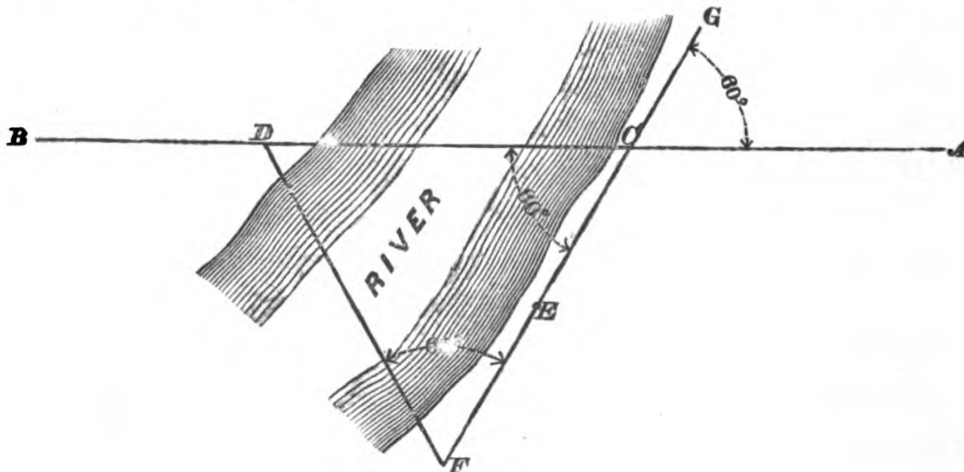

FIG. 6.

as shown in the figure. Then fix the point  $F$  in line with  $E C G$  so that the angle  $F C D$  shall be 60 degrees. Now measure  $F C$ , which will be equal to  $C D$ .

Many will say, why erect the pole G? I erect it to lengthen the line E C for observation and to check the accuracy of my work with the sextant.

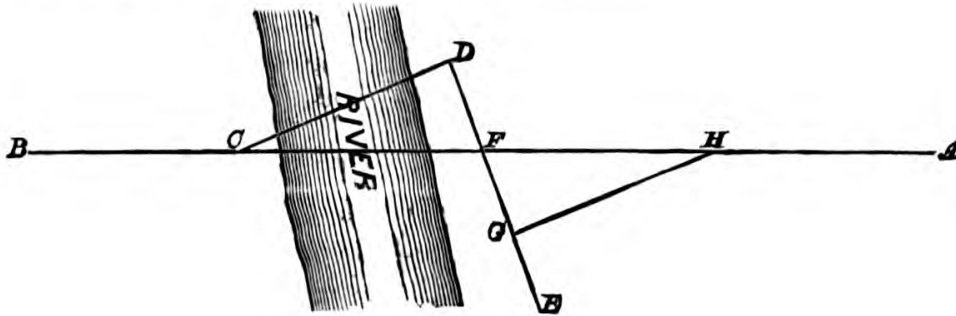

FIG. 7.

In Fig. 7 A B is measured as heretofore. F C is the distance to be calculated with the chain, aided by either the sextant or optical square.

A pole being erected at C, set up the pole D at any convenient spot and erect a pole at E at right angles to C D and at any convenient distance from D. Then erect a pole at F on the point where the line D E crosses the line A B and measure the distance D F. Next set out the distance D F in the direction of E and set up a pole at G, and at right angles to G D erect the pole H in the line A B. Now measure H F, which will be equal to F C.

Of the three described systems for ascertaining the measurement of inaccessible distances Fig. 6 is decidedly the best, and the system I have always employed—Fig. 7 in my opinion taking the second place. In Fig. 5 the slightest inaccuracy in measurement—even such as would be produced by using a tape slightly out of adjustment—would materially affect the length of the line to be calculated.



## CHAPTER VI.

### THE THEODOLITE—SETTING OUT LINES WITH THE THEODOLITE.

THE theodolite is the only perfect angular instrument. The instrument I recommend is the 5-inch plain theodolite—the transit being less compact, more expensive, heavier, and not so easy to adjust.

The theodolite is principally used for taking horizontal and vertical angles, reducing hypotenusal to base measurement, and setting out lines; although it is useful for many other purposes. A perfect instrument carries two spirit levels on the horizontal circle, which is divided into degrees and minutes; a vertical semicircle divided on one side to degrees and minutes, and on the other side to show the difference between the hypotenuse and base of a right-angle triangle; and a telescope and spirit level attached. Attached to that part of the telescope known as the diaphragm, are “cross wires:” these define to the greatest nicety the exact points from which observations are taken.

When the instrument is set up in perfect adjustment, the telescope and vertical circle move up and down in a direct vertical line, so that the “cross wires” clearly define every minute object that is in a direct line with the centre of the telescope.

My remarks on the sextant, with reference to its use and adjustment, apply more particularly to the theodolite, inasmuch as that an amateur will, by the unnecessary

amount of screwing and force he is certain to apply, do more injury to a good instrument in one day than a practical man acquainted with its use would do in a year. I am of opinion that any surveyor's charge for a course of instruction on this instrument, might not exceed the value of the damage an amateur would do to a good instrument with only instructions from a book to guide him.

I believe it will be generally admitted that all the principal lines of an extensive survey should be set out with the theodolite. With this instrument placed in a judicious position, a considerable length of line can often be set out without removing it. The surveyor should have a small flag on one of his ranging poles, to direct his assistant when he is at too great a distance from him to hear, or to distinctly see a motion of the hand.

To guard the pupil against an inefficient course of instruction\* upon this instrument, I will remark that he should be particularly well acquainted with every detail of its adjustment, as the results of ignorance on this head are disappointing in the extreme. Special care should always be bestowed upon the adjustment of the telescope and diaphragm when the instrument is to be used for setting out lines.

---

\* The author undertakes to give instructions upon surveying, levelling, &c.

## CHAPTER VII.

### REDUCTION OF THE MEASURE OF UNDULATING GROUND TO HORIZONTAL MEASURE AND TABLE OF VERTICAL ANGLES.

A GOOD practical knowledge of this highly important department is the principal essential of a good surveyor.

A survey conducted ever so well in every other respect, is indifferently or well made, in proportion as this branch of the profession is carelessly or accurately performed.

There are six distinct methods of reducing the measurement of hills to horizontal measurement.

The first method is that of levelling the chain. To perform this, on the descent of a hill, let the surveyor place his end of the chain close to the ground, and the chainman hold say, fifty links (more or less in proportion to the steepness of the ground) of the chain as nearly level as he can and drop an arrow: then let the surveyor come forward, and hold the chain at fifty links close to the ground, and the chainman hold up the end of the chain and drop the arrow as heretofore. In ascending a hill this operation is reversed.

The second method is likewise by levelling the chain in steps—the only difference being that a heavy plumb bob is used instead of an arrow.

The third method is by taking the vertical angles of all the changes of inclination with the theodolite, and making the necessary reductions between the hypotenuse and base in accordance with the table at the end of this chapter.

The fourth method is by reading from the back of the vertical circle of the theodolite at every change of inclination or slope of the ground, the deduction to be made from each chain's length for the difference between the hypotenuse and base of a right-angle triangle.

The fifth method is only available in special cases, and consists of a calculation of the length of a hilly line from the measurement of other lines and the angles taken with the theodolite.

The sixth method is performed by a divided semicircular board known as the reducing board. (*Vide* Fig. 8.)

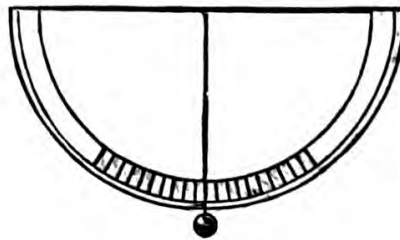

FIG. 8.

This board is divided, to shew the difference between the hypotenuse and base on each chain's length, to every eighth part of a link, in the same manner as one side of the vertical circle of the theodolite, and, being about nine inches in length, can be conveniently carried in one of the coat pockets named in the first chapter.

A plumb bob is suspended from the centre by means of a fine cord, as shown in the cut.

As, to the best of my knowledge, there is no work on mathematical instruments giving an account of this instrument I will briefly describe the method of using it.

Let the surveyor stand close to his chainman on a piece of level ground, and note the exact part of that man which is upon a level with his eye, then let him stand in an upright

position at one end of the chain, and take sight—as aiming with a gun—along the top of the board to that part of the chainman already noted, who will be at the other end of the chain, when the top of the board will be upon the same inclination as the ground and parallel to it. Now turn the board on one side and the difference between the hypotenuse and base will be shewn by the cord crossing the graduated scale.

If the surveyor will bend his back a little and apply his eye to the ground, he will often discover a gradual descent or rising of many chains in length—in this case one sight with the board will suffice for the entire length of slope.

After giving a fair trial to each of the six methods, I am decidedly in favour of the reducing board for ordinary work—the theodolite being indispensable in special cases.

I now beg to differ with every work that I have seen upon surveying—it being generally asserted that levelling the chain will do very well when the slope is gentle, but that the theodolite should be used on steep ground.

I believe it to be impossible for any man to level the chain when the vertical angle is, say, for example, four degrees and showing a reduction of about a quarter of a link per chain; because in the first place he must be a correct judge of level, and, secondly, he must be able to hold the chain level.

Any practical man knows that a chain, on account of its weight, cannot possibly be level when one end is held close to the ground and the other held up nearly five feet. Now to level the chain, even for this slight reduction, one end would require to be held up nearly five feet, unless the

surveyor measured fifty links at a time, which I venture to say upon a slope of this kind he would not do. I have found it more the custom to ignore these gentle slopes altogether than to measure a chain's length upon them in two parts.

I do not, however, believe it to be impossible for a careful man to take the correct horizontal measure of a slope requiring a reduction of three links per chain by levelling the chain and using a plumb bob, because, as he could only measure twenty five links at a time, the chain might be kept tolerably level.

The board, in practised hands, has the following advantages :

1. It combines the correctness of the theodolite ;
2. Saves the man's labour who would be required to carry the theodolite ;
3. Saves the time required to set up the theodolite ;
4. Makes the correct allowance for gentle slopes which cannot be made with the chain ;
5. Does at once the work of the many operations required in levelling the chain.

Its fifth advantage is clearly its best, because it effects a great saving in time and avoids the error created by a multiplicity of unnecessary operations.

Leaving the pupil to select that one of the six methods which best pleases him, I cannot pass this part of my subject without impressing upon him how important it is that the reductions to horizontal measurement should always be made in the field. An altered or copied field book is always looked upon with the eye of suspicion, and justly so, because, admitting the strictest integrity on the part of the surveyor, he would be almost certain to make some mistake or omission in correcting or copying a volume



of figures. It is only in an exceptional case that a vertical angle is reduced in the office by the following table :

*Table showing the reduction in links from each chain's length for the following vertical angles.*

Angle.	Reduction in links.	Angle.	Reduction in links.	Angle.	Reduction in links.
° /		° /		° /	
3·0	·137	8·45	1·16	14·30	3·18
3·15	·161	9·0	1·23	14·45	3·29
3·30	·187	9·15	1·30	15·0	3·40
3·45	·214	9·30	1·37	15·15	3·52
4·0	·244	9·45	1·44	15·30	3·63
4·15	·275	10·0	1·51	15·45	3·75
4·30	·308	10·15	1·59	16·0	3·87
4·45	·343	10·30	1·67	16·15	3·99
5·0	·381	10·45	1·75	16·30	4·11
5·15	·420	11·0	1·83	16·45	4·24
5·30	·460	11·15	1·92	17·0	4·37
5·45	·503	11·30	2·00	17·15	4·49
6·0	·548	11·45	2·09	17·30	4·62
6·15	·594	12·0	2·18	17·45	4·76
6·30	·643	12·15	2·27	18·0	4·89
6·45	·693	12·30	2·37	18·15	5·03
7·0	·745	12·45	2·46	18·30	5·16
7·15	·800	13·0	2·55	18·45	5·30
7·30	·856	13·15	2·66	19·0	5·44
7·45	·913	13·30	2·76	19·15	5·59
8·0	·973	13·45	2·86	19·30	5·73
8·15	1·03	14·0	2·97	19·45	5·88
8·30	1·09	14·15	3·07	20·0	6·03

## CHAPTER VIII.

### MEASURING LINES, THE OFFSET STAFF, AND TAKING OFFSETS.

BEFORE proceeding to measure any line, always let your chainman count his arrows and see that he has ten. Next see that he puts three or four of his fingers through the handle of the chain, and with his thumb holds one of the arrows close to the outside of the handle, and at about two inches from its point. No surveyor will make accurate work if he uses long arrows and allows his chainman to hold them at the top. The chainman thus puts down his arrow at the end of each chain, to be picked up by the surveyor. When the chainman has put down his tenth arrow, the surveyor should come forward, mark the point with his offset staff, pick up the arrow, and give ten arrows to the chainman, who will proceed as heretofore. In putting down an arrow the chainman should always stand with a square front to the surveyor, whose duty it is to see the arrow put down truly in the line. A chainman standing in any other position, cannot possibly put down his arrow correctly and at the same time leave the chain truly in line and perfectly straight upon the ground. If the chain be laid out of line, the offsets will be measured either too long or too short, the consequences being a bad plan, and the computation of an incorrect area.

The offset staff is a straight light pole divided into links, and ten links in length: it should be shod with an iron



spike at one end, and fitted with a small hook, for the purpose of pulling the chain through the hedge, at the other end.

Offsets are measurements taken at right angles from the chain to the boundaries of property, or to such objects within the boundaries as are required to be shown on the plan. Both for purposes of calculation, and to enable the surveyor to make an accurate plan, an offset should be carefully measured from the chain to every bend, turn, or angular point in a boundary.

The printed instructions of the Tithe and Inclosure Commissioners—which a surveyor can obtain gratis—clearly set forth that no offset shall exceed a chain in length, and as a broad rule this is a very good one.

There is, however, no doubt that the Commissioners, irrespective of their good rule, would much prefer the surveyor to have a rule of his own to generally limit the length of offsets to fifty links.

Every long offset taken to the junction of fences, or to any decided angular point, should be measured with the tape and set at right angles to the line with the optical square.

---

## CHAPTER IX.

TO PROVE THE CORRECTNESS OF OBSERVATIONS TAKEN WITH THE SEXTANT—SINGLE FIELDS MEASURED WITH THE CHAIN AND OPTICAL SQUARE, SO THAT THE AREAS CAN BE DIRECTLY CALCULATED.

It is not only the duty of a surveyor to do his work accurately, but it is necessary that he should prove it to be so. For instance, a surveyor might, with the sextant, take a certain number of angles correctly, but unless he has proved their accuracy he could not *declare* he had done so. The following are problematical proofs.

1. The sum of the three interior angles of any triangle is equal to two right angles or one hundred and eighty degrees.
2. The sum of the four interior angles of any four-sided rectilinear figure is equal to four right angles or three hundred and sixty degrees.
3. All the interior angles of any rectilinear figure, together with four right angles, are equal to twice as many right angles as the figure has sides.

Although further systems of proof could easily be quoted, I consider the foregoing quite sufficient — the pupil, however, would do well to study carefully the first book of Euclid.

The direct mode of dealing with any subject is always the best: therefore the most correct mode of ascertaining the area of a field is to calculate it from the field notes.

In Fig. 9 a triangular shaped field is measured. The fine lines represent the lines of measurement: the thick lines the fences. The marks T on the fence lines, show the side to which the fence belongs—*i. e.*, that the fence does not belong to the field. The points in the lines from which other lines branch, are called stations and are marked thus ⊙. On one side of the fine lines are the length measurements in links; on the other side the offsets.

The base line A B is measured from A to B; the perpendicular from three hundred and fifty links on the base to C; and the other lines from C to A and B respectively. The perpendicular must be set at right angles to the base with the optical square.

To calculate the area of a triangle, multiply the base by half the perpendicular, and the length from one offset to another by the average of the two offsets, thus :=

Base = 770.	Perpendicular = 282.	
		770 × (282 ÷ 2) = 108570
Offsets on A B =	{	350 × 18½ = 6475 190 × 24 = 4560 230 × 13½ = 3105
Offsets on B C =	510 × 17 =	8670
Offsets on C A =	{	40 × 11½ = 460 90 × 22½ = 2025 120 × 17 = 2040 80 × 14 = 1120 30 × 18 = 540 40 × 25 = 1000 44 × 15 = 660
Piece curving 5 links on C A =	44 × 3 =	132
	Acres	1.39357
		4
	Roods	1.57428
		40
	Perches	22.97120

Thus, this field should be said to contain 1a. 1r. 23p.

I will here observe that the surveyor will find many advantages in the use of small figures in his field notes and

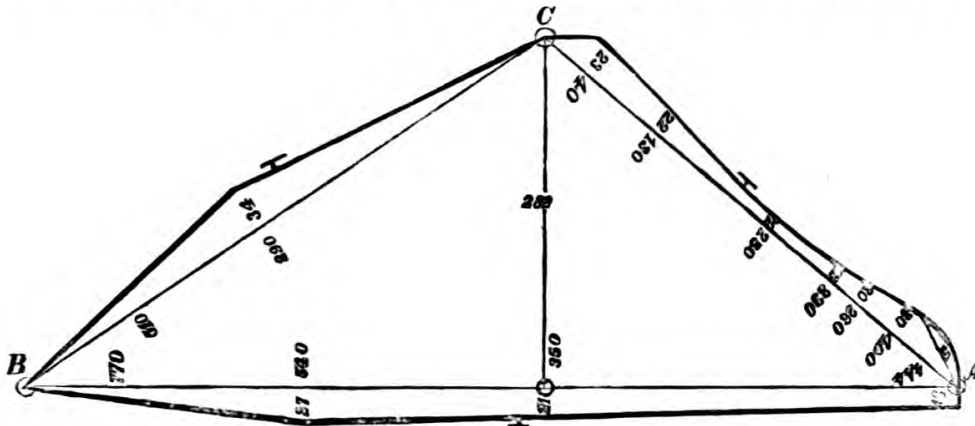

FIG. 9.

calculations. I was never acquainted with a good surveyor who used large ones.

In Fig. 10 a trapezium is measured, but which, to adhere

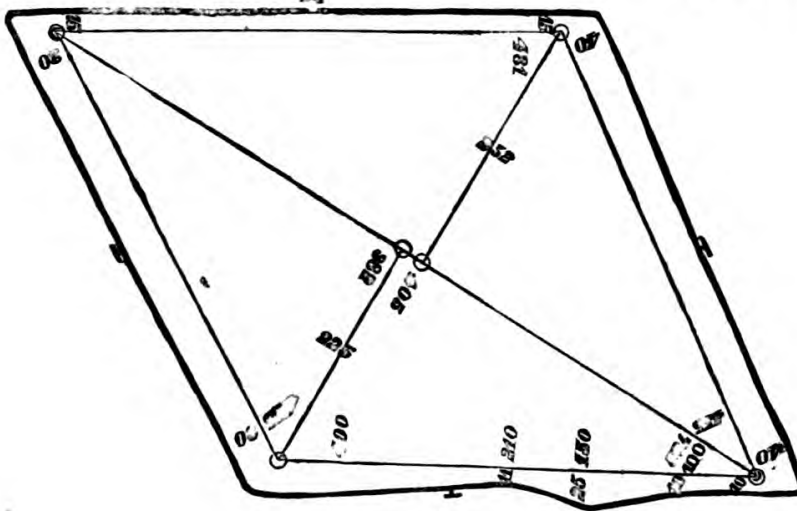

FIG. 10.

to Chap. II., we will call two triangles with a base common to either.

To calculate the area of this field, multiply the base by half the sum of the two perpendiculars, and calculate the offsets in the manner already described.

Whilst upon the subject of offsets I will stop to condemn the absurd system for their calculation often taught in certain schools, and practised by agriculturists, viz.—that of adding all the offsets on one line together and dividing the sum by their number for an average offset applicable to the whole line.

The area of a parallelogram or square is obtained by simply multiplying the length by the breadth.

The area of a circle is obtained by multiplying the diameter by itself and the result by  $\cdot7854$ .

Although in calculating the area of the triangle (Fig. 8) I have worked out the decimals of the acre by multiplying by 4 and 40, it is not the practice usually adopted. Most surveyors of experience are so well acquainted with the decimals of an acre that they know *at sight* how many roods and perches any decimal represents.

This, however, is not expected from the beginner, for whose use I append the following table of decimals and equivalents.

Decimals	Perches.	Decimals	Perches.	Decimals	Perches.	Decimals	Roods.	Perches.
$\cdot006$	1	$\cdot087$	14	$\cdot169$	27	$\cdot90$	3	24
$\cdot012$	2	$\cdot094$	15	$\cdot175$	28	$\cdot80$	3	8
$\cdot019$	3	$\cdot100$	16	$\cdot181$	29	$\cdot75$	3	0
$\cdot025$	4	$\cdot106$	17	$\cdot187$	30	$\cdot70$	2	32
$\cdot031$	5	$\cdot112$	18	$\cdot194$	31	$\cdot60$	2	16
$\cdot037$	6	$\cdot119$	19	$\cdot200$	32	$\cdot50$	2	0
$\cdot044$	7	$\cdot125$	20	$\cdot206$	33	$\cdot40$	1	24
$\cdot050$	8	$\cdot131$	21	$\cdot212$	34	$\cdot30$	1	8
$\cdot056$	9	$\cdot137$	22	$\cdot219$	35	$\cdot25$	1	0
$\cdot062$	10	$\cdot144$	23	$\cdot225$	36	$\cdot20$	0	32
$\cdot069$	11	$\cdot150$	24	$\cdot231$	37	$\cdot10$	0	16
$\cdot075$	12	$\cdot156$	25	$\cdot237$	38			
$\cdot081$	13	$\cdot162$	26	$\cdot244$	39			

The area of every field which cannot be measured on the ground as a triangle or trapezium, as in Figs. 9 and 10, will be best computed from paper in the office in manner hereafter described.

This is one of the chapters in the treatise that might—had I not promised to avoid abstruse calculations—have been lengthened *ad libitum*. On the one hand a considerable number of examples embodying mathematics that might rack the brain could have been described, although in my opinion reference to them would have served no practical purpose; on the other hand, I might have calculated the area of the circle from its diameter, or radius, or by reducing it to another figure of equal area; in fact, upon the question of a circle alone, a high-class mathematician might write a volume, especially as there are points in connection with it that still remain unsolved, or, to say the least, that work out an interminable result.

As I have a very distinct recollection that the books from which I studied as a school-boy always contained examples—and rightly so, for the exercise and proper development of the matter contained within the cranium—more simple than the questions at the head of which they were placed as guides or rules, I have illustrated this chapter upon that same system which has served me so well.

## CHAPTER X.

TO SET OUT A RIGHT ANGLE WITH THE CHAIN—FIGURES OF THE LINES OF MEASUREMENT BEST ADAPTED TO IRREGULAR FIELDS.

To set out a right angle from D on the line A B, let C D measure 60 links, D E 80 links, and C E 100 links, when D E will be at right angles to D B. The same

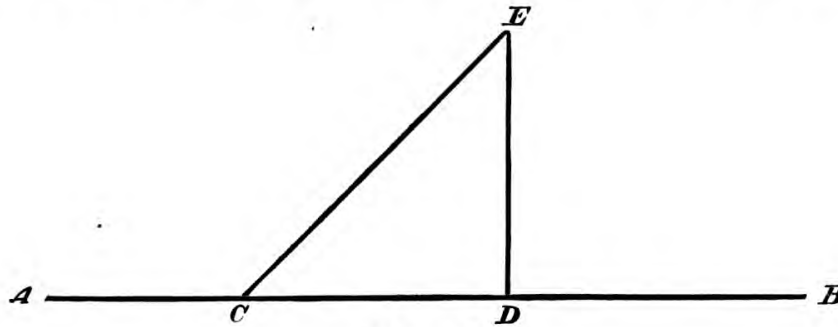

FIG. 11.

result will be obtained by any other measurements bearing the proportions of 3, 4, and 5.

Figures 12, 13, and 14 represent three fields of irregular shape, and the lines best suited to their measurement by triangulation.

Now, in proportion as every engine, instrument, or machine, is better for being constructed in few parts—*i.e.*, is better for having in whole castings or forgings certain parts which might be in many—so is the measurement of a field more correct when it is surveyed by one well-constructed figure embracing the whole area.



Lines produced through other lines, and fixed by means of tye lines, tend as much as anything to form a well-constructed figure.

The frequently adopted system of building one triangle

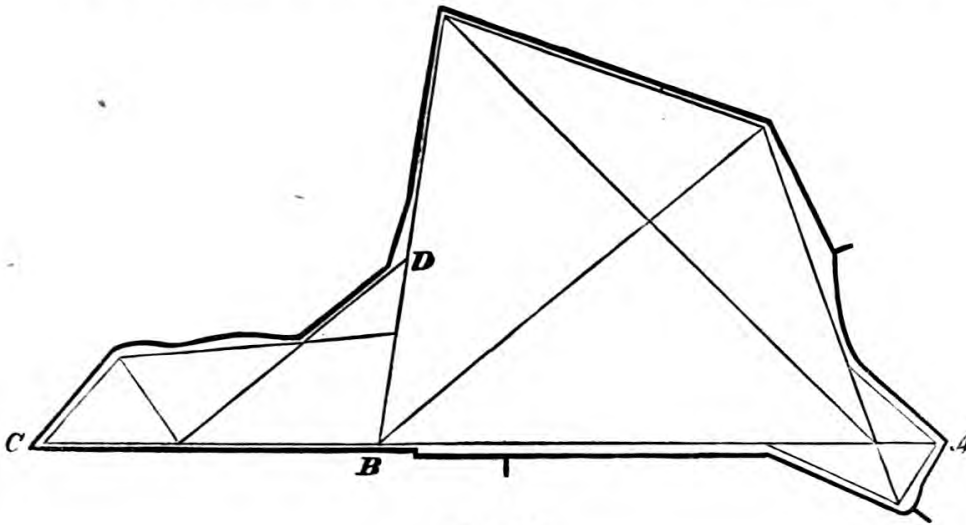

FIG. 12.

upon another, a third upon the latter, and so on, is a bad system; because a slight error in that side of the first

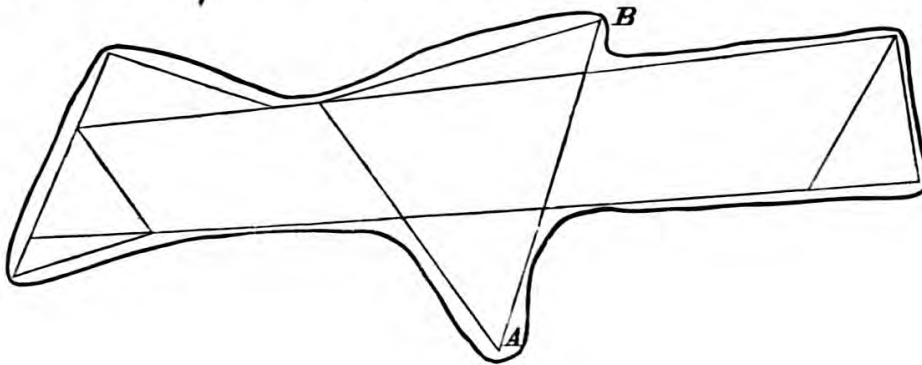

FIG. 13.

triangle upon which the other triangles are afterwards built is carried throughout the construction.

The figures I have given clearly show the value of produced lines.

In Fig. 12 the production of  $A B$  to  $C$  fixes the point  $C$  without further measurement, and keeps the whole of the field in one construction, and that portion to the left of  $B D$  in correct position.

In Fig. 13 the points  $A$  and  $B$  are more accurately fixed by the produced lines than they would be by triangles built upon the two sides.

Fig. 14 is a peculiar construction, but a thoroughly good one.  $A B$  is the base line upon which two triangles are built having sides crossing each other at  $C$ .  $D E$  and  $F G$

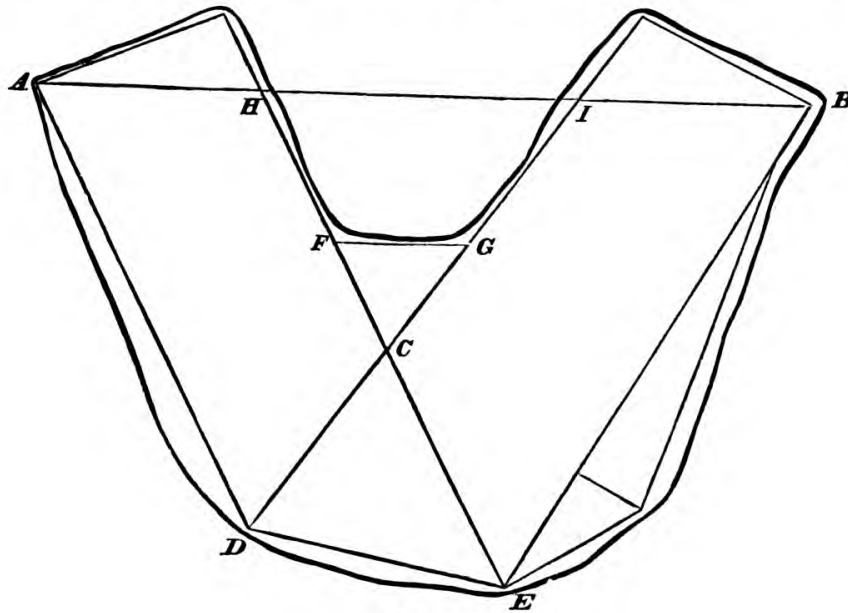

FIG. 14.

are two proof lines. Additional proof is gained by the production of two lines of these triangles through the base, tye lines being measured from their termination to the points  $A$  and  $B$ .

Now many might say, why measure  $H I$  on the line  $A B$ ? Independently of this you have a good construction. I assert, the construction is faulty without the entire measurement of  $A B$  as a base. If  $H I$  were not measured, the

probability is that the points A and B would not be correctly fixed, as the field would be surveyed by the untied productions of two sides of the small triangles E D C and C F G.

A rule in construction never to be forgotten is, that you may make a short production of a long fixed line, but not a long production of a short one. Another rule is always to fix the end of the line so produced by a tye line.

With these examples, explanations, and rules, I must leave to the ingenuity of my pupil the construction of such figures as are necessary in the surveys of single irregularly shaped fields, at the same time telling him plainly that loose or careless construction is always productive of a bad survey.

In Figs. 12 and 13, I have presumed the boundaries to be hedge and ditch fences belonging to adjoining owners; I have, therefore, to avoid damage to the fences, and to enable me to take my offset measurements more accurately, kept my lines of construction quite within the fields. Had the boundaries been of a different character, and their ownership otherwise than described, the construction of both figures could easily have been improved upon; for instance, in Fig. 12, a better construction could have been obtained by measuring a line from C to the highest point in the figure; and again, an improved construction for Fig. 13 would have been a triangle set out by lines crossing the fences in several places, the base being along the upper part of the figure, the apex being at A.

---

## CHAPTER XI.

### EQUALISING BOUNDARIES, AND DRAWING A TRIANGLE EQUAL TO A GIVEN FIGURE.

EQUALISING a boundary consists, as might naturally be supposed, of drawing a straight line from one point of an irregular boundary to another point, in such a manner that the quantity of land on one side of the straight line, and between such line and the boundary, shall be equal in quantity to the land on the other side of the straight line, and between the latter and the boundary as in Fig. 15; A being equal to A, and B to B.



FIG. 15.

To draw a triangle equal in area to a parallelogram.

Let A B C D (Fig 16) be the parallelogram.

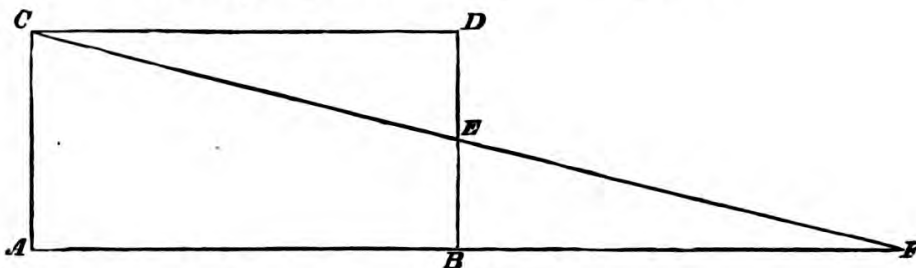

FIG. 16.

Prick off E equidistant from B and D, and produce C E and A B till they meet at F, when the triangle A C F will be equal to the parallelogram A B C D.

To draw a triangle equal in area to a trapezium,

Let  $A B C D$  (Fig. 17) be the trapezium.

Draw the diagonal  $B D$ , extend  $A D$  to  $E$  and draw  $C E$  parallel to  $B D$ ; then draw  $B E$ , when the triangle  $A B E$  will be equal to the trapezium  $A B C D$ .

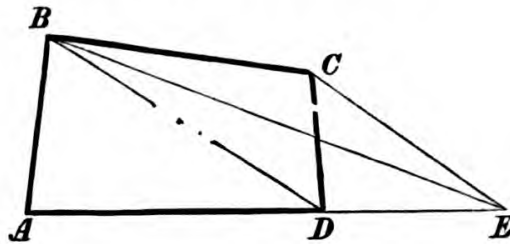

FIG. 17.

To draw a triangle equal in area to a figure of five sides.

Let  $A B C D E$  (Fig. 18) be the figure of five sides.

Extend  $A B$  in both directions and draw  $D A$  and  $D B$ ;

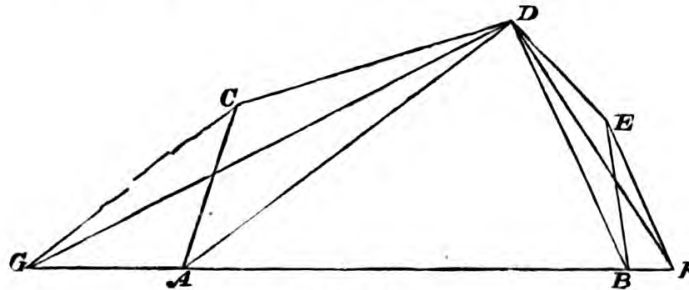

FIG. 18.

then draw  $C G$  and  $E F$  parallel to  $D A$  and  $D B$ , and draw  $D G$  and  $D F$ , when  $G D F$  will be equal to  $A B C D E$ .

I have quoted these old problems specially to make the next chapter more perfect—I do not recollect ever having applied one of them to practice.

## CHAPTER XII.

### COMPUTATION OF AREAS OF IRREGULAR FIELDS.

THERE are five methods of calculating the areas of irregular figures.

1. By laying the figure out in triangles with the scale.
2. By means of parallel lines a chain apart.
3. By squares and the sliding computing scale.
4. By drawing a triangle equal to the irregular figure.
5. By cutting a piece of paper to the exact size of the figure, and weighing it in a pair of scales of most delicate finish—special paper and weights being employed.

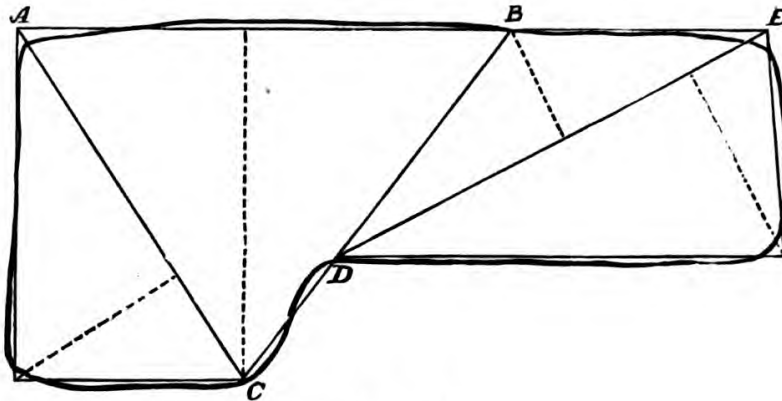

FIG. 19.

Fig. 19 represents an irregular figure to be computed by method No. 1.

First equalise all the boundaries by means of straight lines, then cut the figure into triangles, and next draw the perpendiculars shown by the dotted lines. It now only

remains to calculate the area from the lengths of the bases A C, A B, and D E and the lengths of the perpendiculars, as in Chap. IX.

Fig. 20 illustrates the computation of an irregular figure drawn to the scale of three chains to the inch, by method No. 2.

First draw a straight line touching the top of the figure as in the cut; then draw lines through the figure, parallel to the first line and one chain apart, and next draw the cross parallels shown in the cut to deal with the outlying portion which is less than a chain in width.

Now draw lines to equalise the boundary as shown in the cut, and with the scale measure the lengths (given in the cut) between the equalising lines, add them together, multiply their sum by one hundred links, and the result will give the area, thus:—

360
560
618
584
580
600
90
85
85
90
90
40
3782

$$3782 \times 100 = 378200 \text{ or } 3\text{a. } 3\text{r. } 5\text{p.}$$

The third method is based upon the principle of the second — the differences being that transverse parallels forming squares are drawn upon transparent paper which is laid upon the figure, and that the computing scale equalises the boundary and gives the area without calculation.





## CHAPTER XIII.

### EXAMPLE OF A SURVEY OF SEVERAL FIELDS TOGETHER, AND THE FIELD BOOK.

THE Inclosure and Tithe Commissioners require all field books to be distinctly kept in ink in the field, and do not permit erasures on any account.

When a mistake has to be rectified, the pen should be drawn through the original figures in such a manner as not to obliterate them ; and a note of explanation as to how the error occurred should be written alongside it.

No straight fence shall be drawn upon the plan from the crossings of two lines. Every such fence must either have a line measured alongside it, or at the least be crossed three times, and must have the letters S T written against it in the field book to signify that it is straight.

The lines of measurement should always be shewn on the working plan in red, and should be very finely drawn in. The numbers of the lines should always be written on the plan in the directions in which they were measured. Fig. 21 is an example of a survey of several fields together: following the figure is the field book.

Although I have taken exception to rule by plotting Fig. 21 at eight chains to the inch for obvious reasons, no working plan or map should be made upon a smaller scale than three chains to an inch.

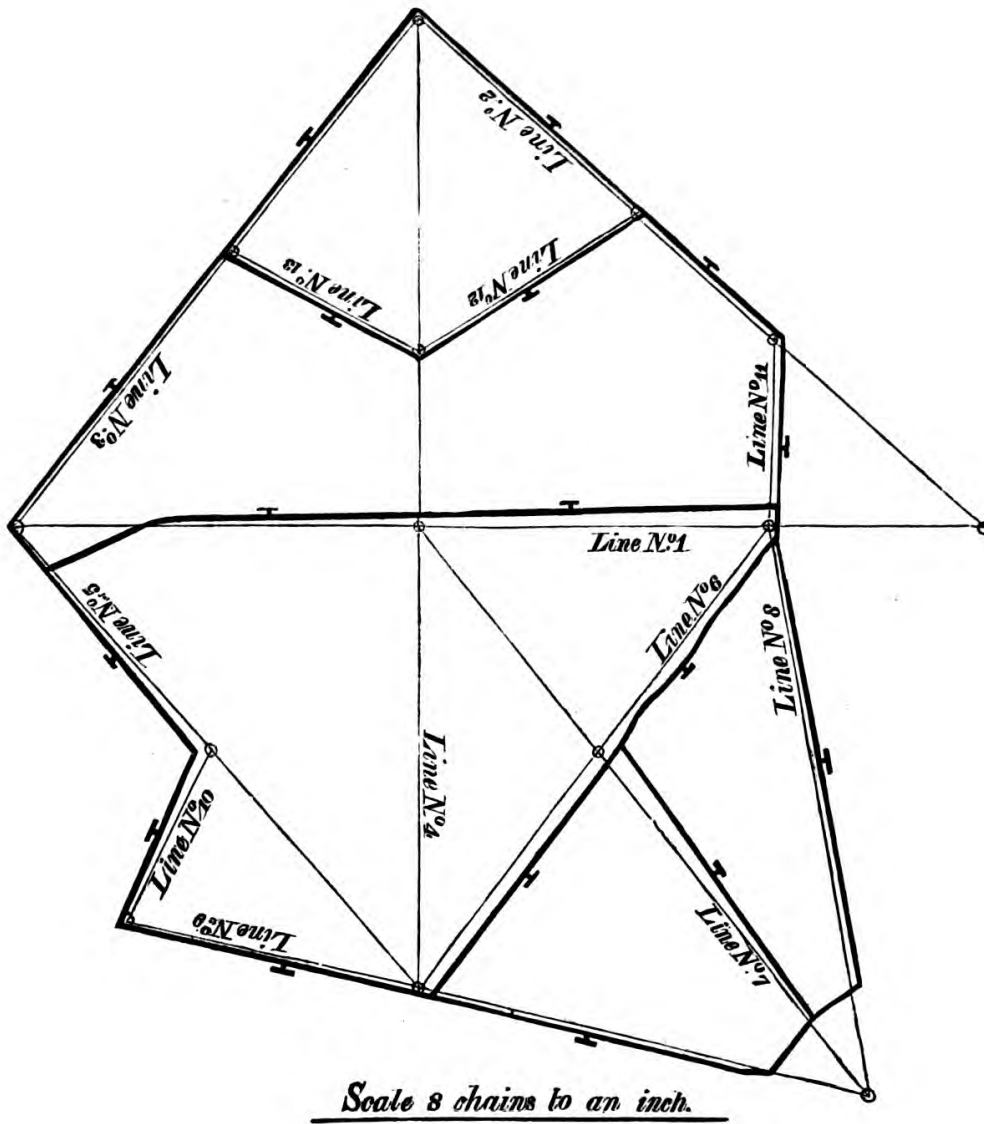
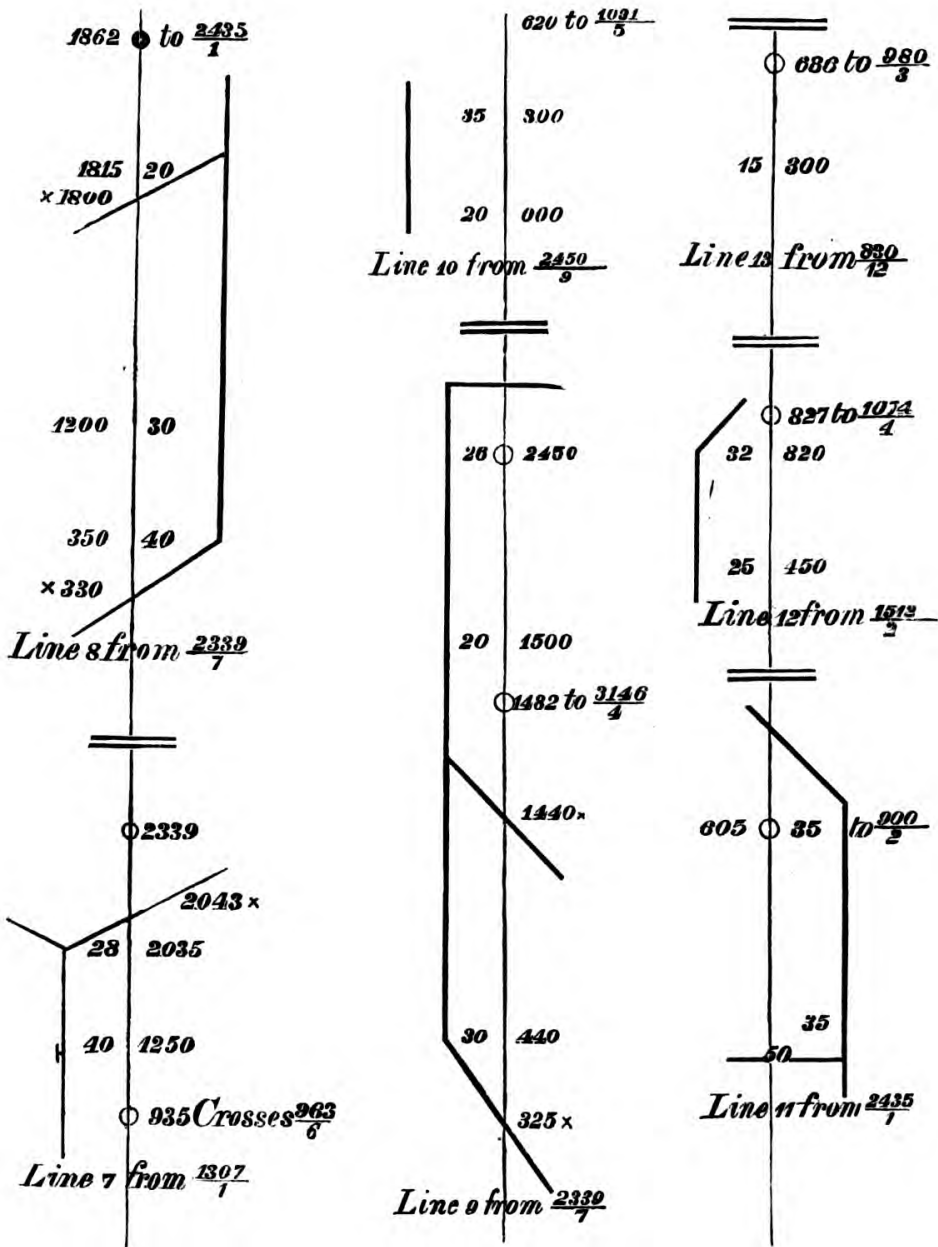

FIG. 21.





FIELD BOOK (continued).

## CHAPTER XIV.

### REFERENCE NUMBERS TO MAPS—TO PUT DETACHED BUILDINGS IN CORRECT POSITIONS ON A PLAN BY MEANS OF UN- MEASURED LINES—LINES MEASURED ON THE WORK— MAKING STATIONS.

It is very important that the precise limits of every piece of land or holding should be clearly defined on the map, and that each piece should have a number attached to it for reference.

When two or more pieces are computed in one area, the same reference number should be put in each piece, or the pieces should be connected by "brackets" thus :—

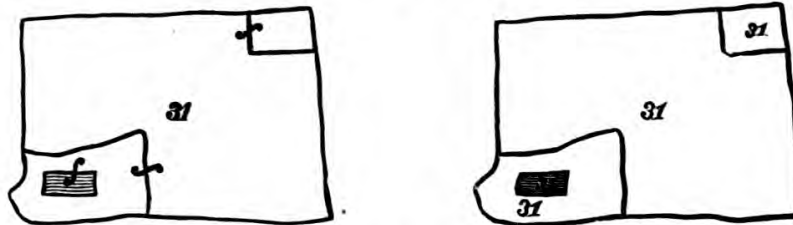

FIG. 22.

The numbers on the map should be placed in the first column of the reference, which should contain five other columns for the name of the owner, name of occupier, description of lands and premises, state of cultivation, and area or extent.

If the centre of a brook or stream, or the centre of a road, forms a limit to the area of the piece, such limit must be shown by a finely dotted line (see Fig. 23).

When the Inclosure or Tithe Commissioners order a survey to be made, the order is usually accompanied by a pamphlet of instructions, a copy of which I advise the pupil to obtain.

The system of putting detached buildings on a plan by means of unmeasured lines is not generally known, although

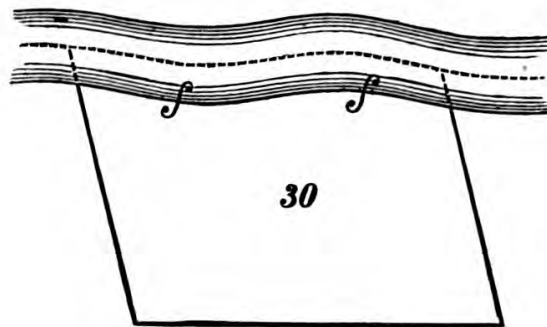

FIG. 23.

I have frequently used it. As compared with the practice of taking offsets, it will be found to give equally good, if not better, results with a smaller amount of labour.

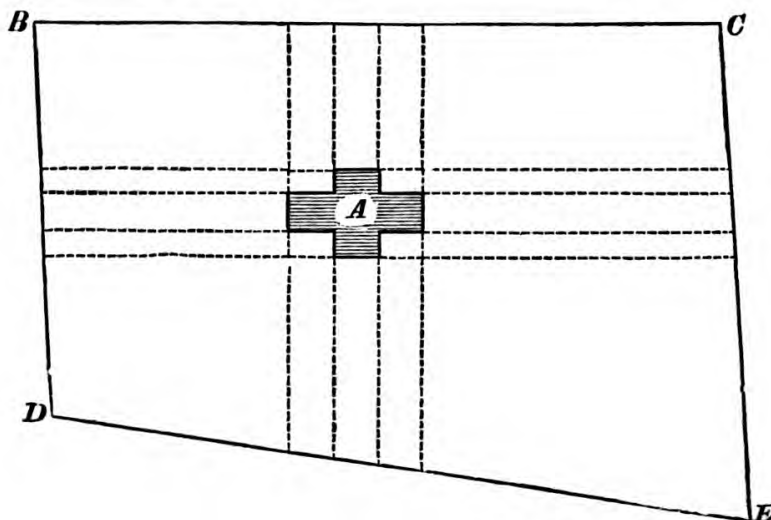

FIG. 24.

Let A (Fig. 24) be a detached building, and the lines



B C, C E, E D and D B, be measured on all sides of A and at any distances therefrom.

Measure the lines B C, C E, E D and D B, and note in the field book the points of their intersection by the produced lines of the sides of the building. Prick off such points on the plan, and therefrom draw in the building as shewn in Fig. 24.

Churches—especially those with buttressed angles—chapels, and many other detached buildings can often be put more correctly on a plan by this method than by any other.

Lines are said to be measured *on the work* when any portion of the property to be surveyed has a straight side that forms the whole or any part of the line to be measured.

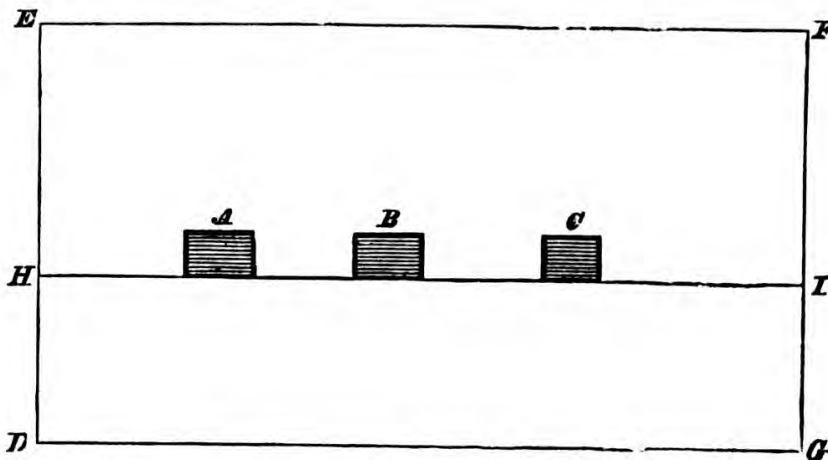

FIG. 25.

Fig. 25 gives an example of a line measured *on the work*. A B C are dwelling houses; D E, E F, F G, and G D are lines in the survey; H I is the line measured *on the work*.

A glimpse at the cut will shew that although the houses A B C might be accurately laid down on paper by means

of offsets taken at right angles from the line D G, they could with greater certainty be laid down from measurements on the line H I.

A line in like manner measured along a straight wall or fence is certain to produce better work than a line measured at a short distance therefrom with offsets to its corners.

This method besides being the quickest and most certain to produce good work, has the following advantages, *viz.*, that the measured line is permanently defined, and that no false stations need be made.

In the conduct of a large survey it will be found advisable in the first place to set out the base line, and secondly to measure it.

Now as, at the time of measuring a base or any other principal line, it is impossible to make stations at the exact points at which the line will be intersected or closed upon by other lines, stations should be made at convenient places, and nowhere should the distance between one station and another exceed ten chains. Stations thus made are termed "false stations."

As the work of the survey proceeds, and as the lines become shorter, the surveyor will be enabled to make his stations exactly where he will require them, these he will call "real stations."

Stations consist of marks or cuts on pasture land shaped to the fancy of the surveyor, stakes or pegs driven into arable land, cuts or notches on gates and rails, and of marks on walls, buildings, &c. A good permanent station can be made in a hard metalled road by letting into it a piece of soft red brick.

When engaged upon the survey of a town or village, the surveyor or his chainman should always carry, for the

purposes of making stations, a hammer, chisel and a quantity of spike rails.

Although I have laid down a broad rule (and a very good one for open country) that stations shall not exceed ten chains apart, it is frequently necessary to make them at much shorter intervals, and it is always advisable to make them at the following places :—

1. On both sides of a road, river, canal, brook, or railway.
2. On pasture land at points in line with fences to either the right or left of the line.
3. In arable fields close to the hedge and out of the way of the plough.
4. At gates and rails by notches cut in the lowest rail.
5. At the outer edge of kerb stones by a cut in the stone.
6. On both sides of a wall or building.

For the purpose of identification hereafter it will be well to make stations in the long lines of a varied character, and to note each variety against the distance in the field book. It may be well to adhere to one character of station as the work advances, and as the lines become shorter.

The surveyor is hardly ever free from difficulties and no man in a book of ordinary size can lay down rules one of which shall always be his guide.

Returning to the subject of stations, it often happens that a vast tract of heath or moor land has to be crossed, and that such land is so gravelly, peaty, boggy, sandy, or otherwise troublesome to deal with, that there is a difficulty in making a good station, and further a difficulty in making such a station as shall be afterwards identified with the entry in the field book. In some such cases I have made

stations by digging large round holes and placing pegs in their centre; in other such cases I have erected a permanent pole. Frequently I have buried in the holes pieces of tightly folded white paper with the lengths of the lines written thereon in soft black lead: these papers can be taken up and read distinctly twelve months afterwards, no matter how bad may have been the weather.

There are however places in towns—as on asphalt pavements for instance—where it is impossible to make a permanent station: in such places the point required as a station must be fixed by measurement.

---

## CHAPTER XV.

### PLOTTING—SELECTION AND MANAGEMENT OF PAPER— INKING IN.

THE branch of the profession termed plotting consists in making the map from the field book or field notes, and in the care and nicety bestowed upon it much depends. No matter how well the surveyor may have discharged his duties in the field, and how correct may be his measurements, the whole is worse than useless unless it be followed by careful plotting upon properly seasoned paper.

Do not attempt any plotting until you have provided yourself with the following necessaries :—

An office table of 2in. dry and well-seasoned deal, 8ft. long, 4ft. wide, and 3ft. 3in. high, a steel straight edge 4ft. in length, a complete set of good drawing instruments and scales, a 6in. circular protractor having two verniers and folding arms, a pair of beam compasses, lead pencils, india rubber, and at least half a dozen leather or cloth covered lead paper weights.

To insure having correctly divided scales purchase them at a first-class maker's, and see that they bear the Tithe Commissioners' stamp. Purchase them in pairs and put the edges together to see that they are perfectly straight.

Firstly, rule a very fine straight line with a hard pencil at the bottom of the paper on which it is desired to make the plan, and prick off on such line the number of chains

that shall be contained in ten inches, according to the scale at which the survey is to be plotted. For instance, if it be desired to plot the survey at a scale of three chains to the inch, and the survey has within it many lines of, say, 100 chains in length, prick off zero a few inches from the left hand extremity of the line, and prick off from it the distances of 30, 60, 90, and 120 chains, and from this line take in the compasses the lengths of all the lines that will be required to be laid down by intersection.

A moment's consideration will show the utility and great importance of this line or paper scale, as paper will expand and contract in a slight degree, notwithstanding all the trouble that may be taken to have it properly seasoned.

Now lay down the base line in such a position that the survey when plotted shall be centrally situated on the paper, regard being had to the position of the north which should always when practicable be at the top of the map. It is often advisable to lay down the lines roughly to a small scale upon a sheet of foolscap paper and to determine therefrom the exact position for the base upon the larger sheet.

The base line being laid down, and the stations thereon carefully pricked off, proceed to lay down all the other lines of measurement as shown and described in Fig. 21 and the chapter referring thereto.

It now only remains to prick off the offsets and draw in the fences, &c., and the work of plotting is complete.

As this work is often both lengthy and tedious, it behoves the surveyor to be scrupulously clean; and upon this head I will add the following recommendations.

1. Put a cover over the table at the end of the day's work.
2. See that the office be well swept every morning.
3. Cure a smoky chimney at any cost.



4. Wash the hands before beginning to work.
5. Keep every kind of ink and colour on a separate table
6. Be careful in pointing a pencil to see that the lead dust falls upon the floor.
7. Look regularly to the covering of the lead weights, and see that it is not worn away at the corners.
8. Do not wear a ring or watch chain when at work : the former is apt to scratch the paper; the latter to mark or soil it when it overhangs the table.
9. Avoid snuff taking.
10. Never leave the window open when leaving the office.

Despite all the good rules on this head that ingenuity can suggest, the surveyor is never certain that he will complete his map without spot or blemish. Sometimes, when candles are used, a moth will fly into the grease and deposit itself on the work; at other times the mouse is his nocturnal enemy.

Although the Tithe and Inclosure Commissioners in their instructions have not mentioned the matter of cleanliness, I cannot help thinking they prefer a clean map to the dirty, inky, snuffy, and almost loathsome document, that I have occasionally seen.

The paper for a surveyor's map or plan should be Whatman's best hand-made double elephant drawing paper mounted upon a good brown or white holland—I prefer the brown holland to the white. It should be procured and laid flat upon the office table at least a week before it is required for use, and should be kept at a uniform dry temperature. As paper expands much in cold or damp weather, and contracts by dryness and heat, the advantages of a thermometer in the office will be apparent.

Many are the surveyors who have experienced trouble



and inconvenience for lack of forethought and management in the matter of the paper.

The fences, boundaries, &c.,—in fact the outline or skeleton map—should always be drawn in Indian ink, and the process of going over the pencil lines of the plotting with such ink is termed “Inking in.” The best Indian ink can be purchased for about ten shillings per stick or piece, and one piece will be a sufficient supply for two or three years. Procure a suitable palette, put into it a large-sized teaspoonful of water, and rub the stick in the palette till the liquid becomes jet black without being thick, when it will be fit for use. Experience alone can tell the amateur when the liquid is black and not thick.

The lines should be jet black, strong, free from shake, and of even thickness, and when magnified, should have their edges sharp and well defined.

“Inking in” is an operation requiring the hand of practice more than anything of an official character with which I am acquainted. No man, however skilful he may be, can possibly succeed in making good work unless his drawing pen be accurately set, and the edge of his ruler perfectly smooth and free from indentation.

No sensible surveyor will use a divided scale for purposes of inking in, because, in the first place, the constant use of the steel drawing pen wears away the delicate feather edge, and, secondly, the ink obliterates the divisions. A surveyor should establish a rule for the office to the effect that “any assistant caught in the act of using a divided scale with an ink instrument, shall pay a fine of one shilling to the poor box in respect of each offence.”

---

## CHAPTER XVI.

### SURVEYS MADE FOR THE PURPOSE OF DIVIDING LAND INTO STATED QUANTITIES.

THE surveys to which the title of this chapter particularly refers, are those made for building estates, and for purposes of inclosure and exchange of land, although it is also applicable to numerous surveys made for other purposes.

As the work of setting out the various classes of allotments, roads, watercourses, &c., under an inclosure, of setting out building lots, and dividing land for purposes of exchange, is often extended over a considerable period—in many cases as long as three years after the completion of the survey—it is necessary that the surveyor should leave upon the ground along all his principal lines of construction, good, permanent, and well-defined stations: I think I shall not err in recommending him to drive stakes of heart oak at the beginning and end of every long line, and at the principal stations upon such line. It would be well, to more particularly define the exact point of an angular observation, to drive a nail into the top of the oak stake. The stakes used for this purpose should be about two and a half inches square, and fifteen inches long, and they should be driven in nearly level with the ground.

I cannot pass this part of my subject without remarking upon the careless manner in which I have seen stakes driven in, and a word of recommendation as to the only proper method of driving them.

The length measurement in the line being determined upon, let the surveyor go to the nearest ranging pole on the line—unless he erects one specially for the purpose, or uses a theodolite—and so direct his assistant that the latter shall put down the stake truly in line. Now, with an axe, beetle, or other suitable instrument, let the stake be driven in, but be careful to see that the driver stands front and rear truly on the line, or he cannot possibly avoid driving in the stake a little to one side, and thus staking out a crooked line from which no reliable observation can afterwards be taken. It is generally the practice for the driver to stand at one side of the line, and it is a practice that cannot be too strongly condemned.

Some years ago I was called upon to set out the allotments under a large inclosure in Essex from a survey which, to the best of my recollection, had been made three or four years before by a surveyor with whom I was not acquainted, and I have a distinct recollection of the pleasure the work afforded me, and how much such work was simplified by the great pains which had been bestowed in staking out the lines.

In this inclosure the allotments were set out from one side of the survey to the other side through a dense wood, and were commenced from an angle taken by a theodolite from one of the principal lines. My pleasant recollection of this work consists in the fact that after continuing my lines through the wood for nearly a mile they closed in some instances exactly upon the calculated point, and in every other instance within a few inches of it.

Now picture to yourself, if you can, the consequences that would have followed if a line had not closed upon the calculated point! Horrid are they to contemplate!

They would have involved the calculation of the angle of

deviation, a return to the point of commencement, the cutting of a new line through the wood at great expense, the loss of much valuable time, and an exhibition of blundering of which one is always ashamed—and all this would have occurred had the lines of the survey been less carefully staked out.

---

## CHAPTER XVII.

### SETTING OUT ALLOTMENTS AND BUILDING PLOTS.

THESE should in the first place be carefully set out on the plan, and the measurements from which the areas are computed should be put upon a tracing specially prepared for uses in the field: this tracing should always be carefully preserved.

To set out allotments correctly on the ground, always measure from the lines of the survey, and not from the fences.

In measuring along a straight line to stake out the junctions of several new fences, always let the measurement be a continuous one, as error is apt to creep in by measuring first one small piece and then another, and do not forget that in this work, as well as in the survey, true horizontal measurement must be taken.

Fig. 26 is an illustration of a plan showing the areas and measurements of several allotments as prepared for use in the field.

In measuring for allotment purposes, every division of a chain should be carefully measured with the tape, and the length of any line should always be measured till it closes on some given point as a proof to the operations.

Reference to Fig. 26 will show that the line A B is 15·20 chains in length from one station to another, and that it crosses a fixed point in a line on the survey at 7·15 chains.

Drive stakes at the junctions in the manner described in the last chapter, and drive nails into the tops of the stakes to define exactly the points of convergence and divergence. Let the nails stand about a quarter of an inch above the level of the tops of the stakes, and drive intermediate stakes not more than two chains apart in all the straight lines.

If the ground be firm pasture, strain a line of fine cord from nail to nail, and with a sharp spade nick out the new line of fence.

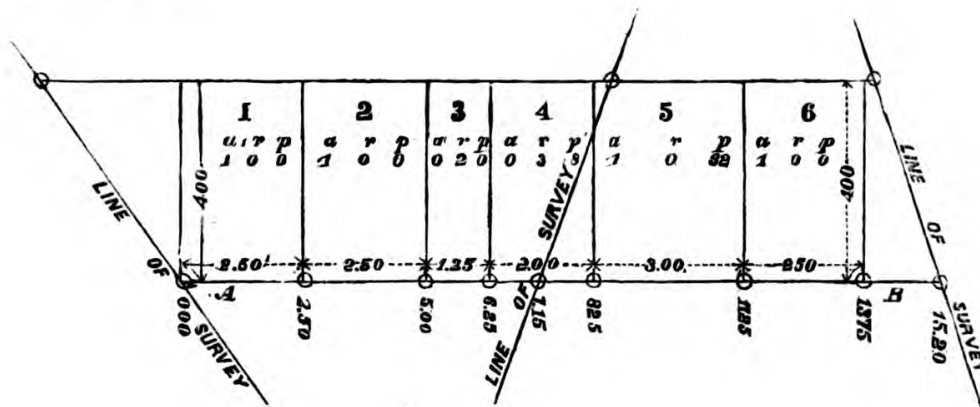

FIG. 26.

When a person is employed as a surveyor in the matter of an inclosure and is not likewise appointed valuer, he has not always the control he should have in arranging the new fences: for instance—it is quite possible, in order to give to each party interested his proper proportion of fencing, to entirely ignore the question of surface drainage, and to place the ditch on that side of the fence which the level of the land shall point out as wrong. To remedy this I would suggest that when allotments are set out on paper, and before any other step be taken, the land should be viewed, and if necessary levels should be taken to see that the work is of a thoroughly practical character,



and that there is a proper discharge for the surface water.

I must here make a little divergence, and, as I have referred to it, speak upon the art of levelling.

It was my original intention to combine with this little work a treatise upon levelling, but finding the latter to be so ably and clearly treated upon, I ultimately considered it better to abandon the idea and recommend the reader to peruse existing works on the subject.\* Singular to say, closely as the two matters are connected, surveying has not been dealt with in the same clear and simple manner.

To return to our subject, let me impress upon the surveyor the necessity of always laying out fences in such a manner as to avoid carrying any surface water away by underground means, and always to let this be his maxim—“All surface water to be carried away by furrows, ditches, and open watercourses. Pipes only to be used for underground drainage.”

When a surveyor is called upon to set out new fences to regulate matters of exchange, or to divide lands for purposes of sale or otherwise, let him always be wise enough, whenever such division comes between, arable and pasture land to have his ditch in the arable field.

It is a difficult matter—in fact, I believe, without incurring great expense, it is impossible—when a ditch is in a pasture field to keep cattle out of it. I have known boundaries much damaged and valuable cattle sacrificed for lack of forethought in this simple matter.

Building plots should always be measured in feet and inches and in every case the frontage and depth should be shown in figures on the plan.

When called upon to divide a frontage, measure its entire

---

\* Vide “Levelling,” by Sims.



length, then measure off the piece first required to be sold, and afterwards measure the remainder to prove the accuracy of the work. Repeat this operation at every sale, or you will be certain to find a difference between the last piece on the plan and the last plot on the ground, which, besides creating much that is unpleasant, might end in a law suit or damage to your professional reputation. Bear in mind you are employed as a surveyor because you are considered reliable.

It is always advisable to see that the builder commences his work properly and that he does not encroach upon the remainder of the estate by any overhanging eaves, barges, spouting, stone weathering, &c.

---

## CHAPTER XVIII.

### ANGLES AND BEARINGS, AND USE AND ADJUSTMENT OF CIRCULAR PROTRACTOR.

WHEN the character of a survey is such as to require many angular observations, they should either be taken on the ground in the form of bearings, or afterwards be converted into such.

Bearings are simply angles from a line of commencement which is severally styled "the base," "the line of departure and close," and the "meridian."

I think it will be as convenient for the purposes of this chapter, to style the line of commencement the "base line," particularly as I fail to see how it can possibly be associated with the meridian.

Fig. 27 is a figure of five sides, shewing the interior angles as taken with a pocket sextant, A being zero, or the point of commencement, and A B the base line. This figure is also intended to illustrate the conversion of the angles into bearings from the base line, and to show a correct and simple method of laying down on the plan in a true position by means of the circular protractor and parallel, the five lines, A B, A C, C D, D E, and E B.

I do not for a moment wish the reader to believe that the parallel to be employed must of necessity be a "parallel ruler;" on the contrary, I pledge myself to the use of the steel straight edge and set square whenever I require to draw a parallel line.

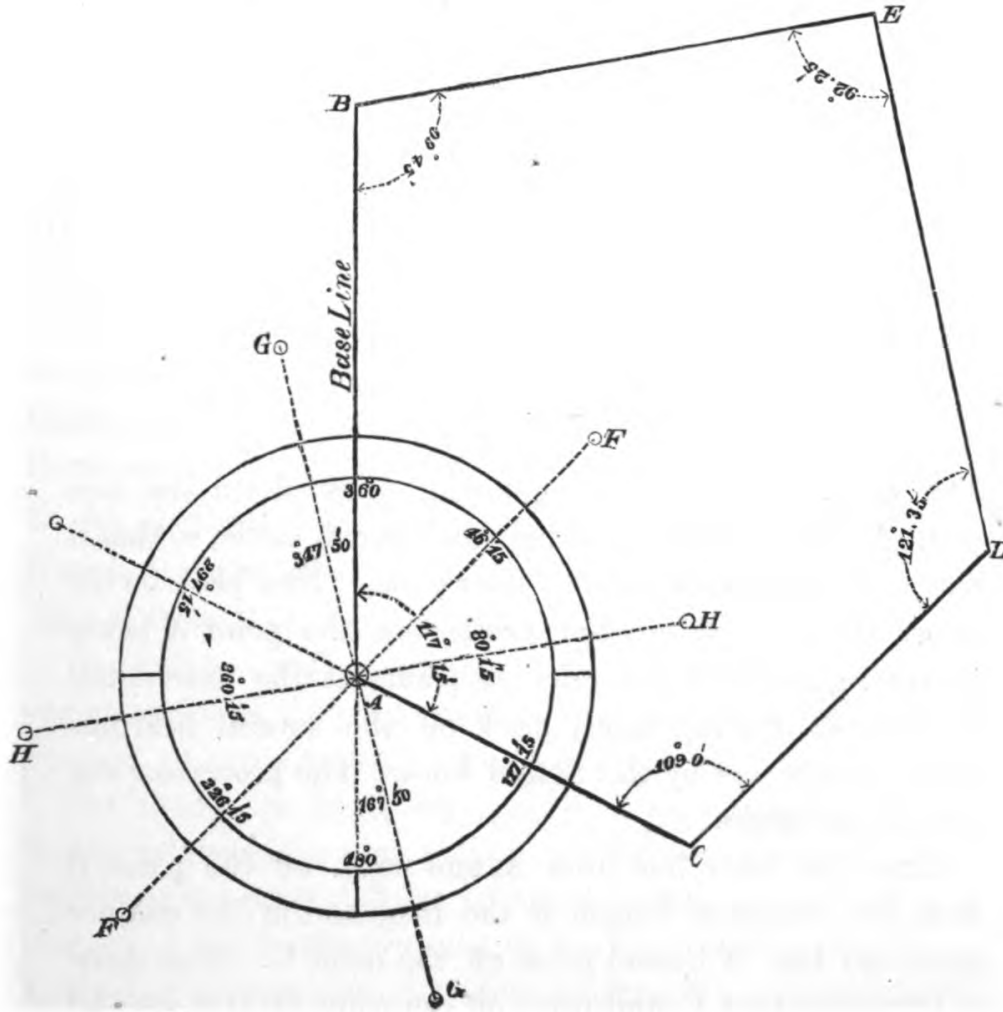

FIG. 27.

To ascertain the bearings, add together all the interior angles, thus :—

Interior angle at A =	117 15	=	Bearing of A C
Add „ C =	109		
	<hr style="width: 50px; margin-left: auto; margin-right: 0;"/>		
	226 15	=	„ C D
Add „ D =	121 35		
	<hr style="width: 50px; margin-left: auto; margin-right: 0;"/>		
	347 50	=	„ D E
Add „ E =	92 25		
	<hr style="width: 50px; margin-left: auto; margin-right: 0;"/>		
	440 15		
Less .....	360		
	<hr style="width: 50px; margin-left: auto; margin-right: 0;"/>		
	80 15	=	„ E B
Add angle at B	99 45		
	<hr style="width: 50px; margin-left: auto; margin-right: 0;"/>		
	180 0	=	„ A B
	<hr style="width: 50px; margin-left: auto; margin-right: 0;"/>		

The bearings being thus obtained, prick down the zero point A, and surround it with a small pencil circle, so that it may not be mistaken for any other point. Now place on the paper the six-inch circular protractor, the point A being its centre, and with the pricking points at the extremities of the two folding arms, prick off the several bearings shown in the cut by the dotted lines. The protractor can now be put aside.

Draw the base line from A, and prick off the point B from the measured length of the line, and in like manner draw the line A C, and prick off the point C. Now draw C D parallel to A F, and prick off the point D, D E parallel to A G, and E B parallel to A H.

If the lengths of the lines be accurately measured and pricked off, and the angular observations correctly taken and protracted, the line E B will close correctly on the end of the base which was pricked off in the first instance.

It is a common custom for surveyors to remove the

protractor and protract each angle separately. I can only say of such a custom it is a very bad one, because, an error in protracting any angle is carried through the whole of the work that remains to be done; whereas, by reducing the angles to bearings, this continuation of error is obviated. Moreover, it is difficult to set the protractor truly upon a line, and removing it damages the plan.

Care should be taken that the protractor is never out of adjustment. When in adjustment the zero, or centre, the divisions of  $180^\circ$  and  $360^\circ$ , and the pricking points at the extremities of the arms, will form a straight line.

In stating that the angles in Fig. 27 were taken with a sextant, I had not lost sight of the stated fact that angles taken with it become less reliable beyond 100 degrees. I therefore recommend that the angle of  $121^\circ 35'$  at the point D, be obtained from a double observation, or calculated from the angle taken from a production of either of the lines C D or E D.

In dealing with angles it will be of assistance to remember that "If two straight lines cut one another, the vertical, or opposite angles are equal." \*

The theodolite being the only instrument with which horizontal bearings can be directly taken, and the only angular instrument that can be relied upon in an undulating country, I will briefly describe its use as applied to Fig. 27.

Having ascertained that the instrument is in perfect adjustment† as to level collimation, parallax, &c., set it up directly over the point A, level it, and bisect the point B with the cross wires in the diaphragm of the telescope, at the same time fixing the horizontal circle at zero by means

---

\* Euclid, book i, prop. 15.

† Vide Sims on Mathematical Instruments.

of the clamp screw ; release the clamp screw of the horizontal limb, turn the telescope, and bisect the point C, clamping the instrument at  $117^{\circ} 15'$ . Now remove and set up the instrument over the point C, bisecting the point A, release the horizontal limb, and bisect the point D, when the readings of the verniers will be  $46^{\circ} 15'$ , and  $226^{\circ} 15'$ . Again clamp the horizontal limb, proceed to the point D, and continue the operation to a close in the manner set forth.

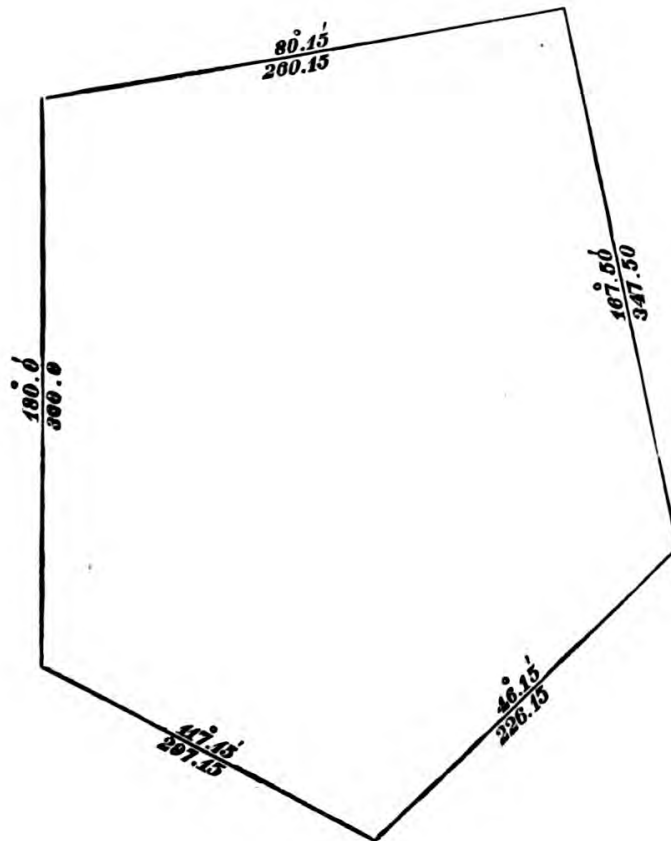

FIG. 28.

If the work be correctly performed, the horizontal circle will be at zero when the instrument is set up over the point B, the point A being bisected with the cross wires.

By this method the conversion of angles into bearings is dispensed with; one operation takes the place of two; mistakes consequent upon unnecessary operations are avoided; and an instantaneous proof is afforded, which needs not a figure of calculation.

Fig. 28 is a facsimile of Fig. 27, shewing the method of registering the bearings in the field from the horizontal limb of the theodolite.

Many surveyors only read one vernier of the theodolite, I, however, recommend that both should be read and the readings registered, the difference between them (180 degrees) acting as a check to error.

Being of opinion that if a thing is worth doing it is worth doing well, I fail to see the use as angular instruments of the prismatic compass, sight compass, circumferentor, sighted cross staff, &c., because they are instruments not made to take angular observations to the required degree of nicety. I look upon the theodolite and sextant as the only reliable instruments for angular observations excepting of course the optical square for a right angle.

---



## CHAPTER XIX.

### TRAVERSE SURVEYS.

WHEN the surveyor is called upon to survey a river, road, canal, or any property of any great length and little breadth, it may be more convenient for him to do so by means of the traverse system than by triangulation.

Traversing is the system of surveying with lines fixed by bearings taken with the theodolite, and it differs from the system described by Fig. 28 inasmuch as that the last line does not close upon the line of departure or base line. When as in Fig. 29 which represents the survey

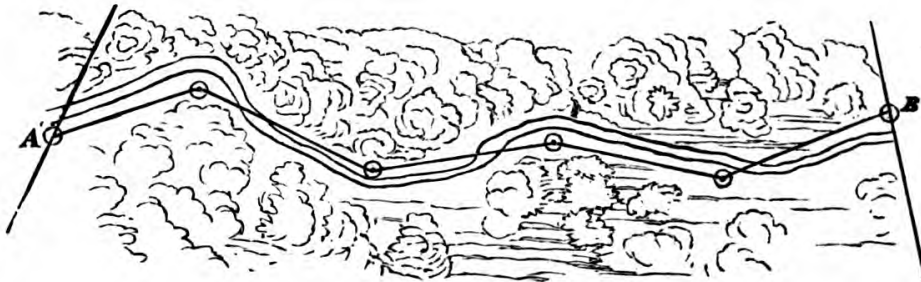

FIG. 29.

of a brook running through a dense wood, the traverse forms part of the detail of a large triangulated survey, and is commenced from station A in one line and continued to station B in another line, the bearings are all taken from the line of departure, the accuracy of the work being proved by the close.

When, however, the survey is conducted upon the traverse system, as in independent construction, it must be carried out in a manner that will admit of proof, and to obtain a good proof I recommend that the lines of the traverse should only form the *principal* lines of the survey, and that the detail should be surveyed by triangulated and produced lines upon and through such principal lines, as shewn in Fig. 30—A B, B C, and C D being the lines of traverse. The work might be further proved by angular observations taken from A to C and D, from C to A, and from D to A and B, if such points were visible from one another.

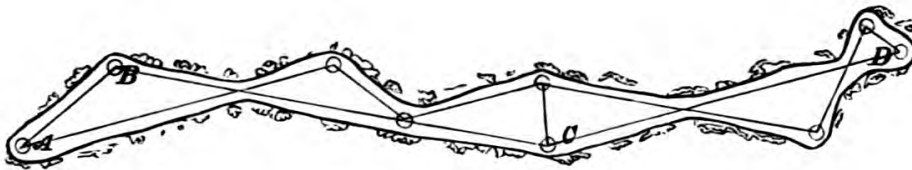

FIG. 30.

During the many years I have been specially engaged upon the field work of a surveyor, I have only made one survey entirely upon the traverse system, such being the survey of a long length of river made for legal purposes in connexion with a fishery rights dispute, yet I have made many surveys of considerable length and little breadth.

With only the above exception I have always made such surveys upon a carefully measured base line commenced at one end of and continued through and to the other end of the survey, and I am of opinion that a base line can, under ordinary circumstances, be set out and measured in considerably less time than would be occupied in taking observations with the theodolite, and apart from this much time would be saved in the office, and the services

of the man who would be required to carry the theodolite could be dispensed with.

That the theodolite possesses a great attraction—I may say a charm—to the beginner, I am fully aware, partly because I was once a victim to it, and because I frequently see young gentlemen, victims like myself, “airing the instrument” as the good woman of the house does certain articles to preserve them from attack by moths.

Excepting for the purpose of taking the angles of the principal lines of construction in a triangulated survey, the beginner should never use the theodolite as an angular instrument, in fact the pupil should never be taught the use of it until he has had considerable experience in surveying by triangulation.

---

## CHAPTER XX.

### TRESPASS.

My inclination for digression tempts me now to say a little upon the matter of trespass, notwithstanding that I believe my remarks would be better received as part of a general and concluding chapter.

It is almost impossible for a surveyor to avoid trespassing, and when engaged upon surveys of intermixed property, outlying parts of estates, projected railway schemes, &c., it is quite impossible for him to do so. The only course I can recommend to him is, to waste no time in asking for permission to cross any property, but to cross it as quickly as possible, and to offer a civil and full explanation of matters if caught, letting the explanation be accompanied by a promise that no damage shall be done. An explanation of this kind I have generally found to answer my purpose when I have met with the owner of the property himself, but I must say I have occasionally met with surly gamekeepers and servants who have taken much to persuade them that my business was actually that of a surveyor, and that I was not a poacher—the inside coat pockets named in Chapter I. being viewed with the eye of suspicion.

When, however, it becomes necessary to measure a line across the residential part of an adjoining or intermixed estate, permission to measure it should most certainly be obtained. I can hardly picture to myself a man who would

be so consummately impudent as to attempt to measure a line of this kind without having first obtained permission.

Surveys of commons for inclosure purposes, and surveys to decide matters of encroachment are nearly always unpopular works; the surveyor must therefore smilingly put up with both insult and abuse, so long of course as the latter is confined to words. I have found that the class of people who resort to these kinds of annoyances can generally be overcome by a little management and good humour; I, however, recollect having encountered some knotty customers.

Looking over some old comic papers—I believe a mixture of “Punch” and “Judy”—I saw a threat dealt with exactly in the words I made use of many years ago.

I was surveying the encroachments upon a certain Royal Forest when a small squatter whose garden I was measuring threatened at once to blow my brains out with his pistol. “My good man,” said I, “you will have to blow some brains in before you can blow them out.” My remark did very well, and the squatter didn’t blow.

I will only add that I have trespassed a great deal without any unpleasant consequences; and that I have completed many very unpopular works without recourse to either force or the law.

---

## CHAPTER XXI.

QUALITY LINES.—SUPERSTRUCTURES AND WORKS UNDERGROUND.—HARVEST AND COPPICE WORK.—REDUCING PLANS FROM A LARGE SCALE TO A SMALL ONE.

THESE are lines of a finely dotted character, and are put upon a tracing of the map to separate the several qualities of the land for valuation purposes: they are never shown upon the map.

It is quite a common thing to find a large field containing land of three or four different values: open tracts of country frequently contain land varying in value from half a crown to fifty shillings per acre or more.

For inclosure purposes the greatest care should be taken in fixing the quantity lines.

As I interpret the term Land Surveying to mean a measurement of everything occupying the *surface of the ground*, it is clearly wrong to show an archway upon a plan as a block building, notwithstanding that the building above the arch may form part of a dwelling house which may be on one or both sides of the archway; and inasmuch as it is incorrect to shew a superstructure on a ground plan or map, it is wrong to shew an underground work by a firm line: underground works and superstructures should be shown on the plan by finely dotted lines.

When, however, the surveyor has to deal with cattle sheds, storage sheds, railway stations, bridges, aqueducts &c., and when the scale at which the map is to be plotted

is not larger than two chains to an inch, he cannot do wrong in shewing block buildings in the cases of the

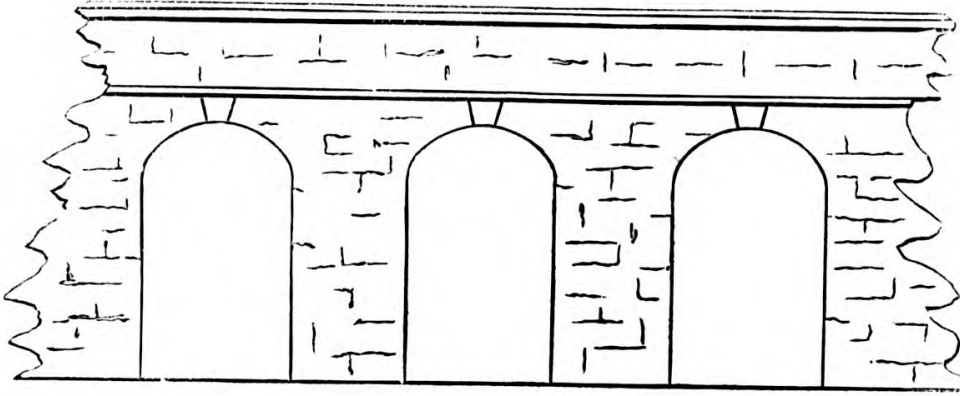

FIG. 31.

sheds, and plain outside boundary lines in the cases of bridges, &c.



FIG. 32.

Fig. 31 represents the elevation of a series of arches and Fig. 32 shews the ground plan of the same.

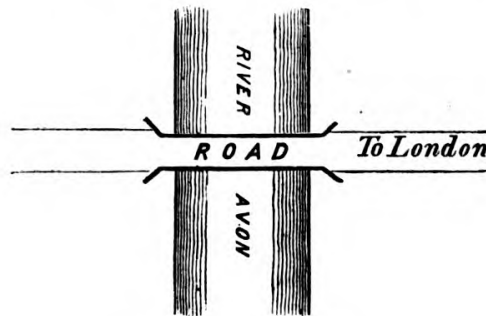

FIG. 33.

Fig 33 is illustrative of a surveyor's plan of a bridge across a river.



The measurement of land taken to decide questions of harvest labour is not worth the notice of the professional surveyor; however, *en passant*, I will remark that it should always be an inside measurement, *i.e.*, it should be the measurement of the land actually cropped with produce belonging to the farmer, and should not include any hedges or ditches.

The measurement of woods taken to enable the owner to settle with his men for cutting, should, as a general rule, be taken in like manner; in some cases, however, underwood is sold under a condition that the purchaser shall properly cut and plash the hedges, when I think it would be only fair to extend the measurement to the outside of such hedges.

In most rural districts there is generally to be found a handy man, a kind of factotum, who undertakes work of this nature.

When the surveyor has the management of an estate or home farm, he should of course take these measurements himself, and where, to work a proper rotation of cropping, large arable fields are always in a variety of crops, he will save time if in the first instance he makes a careful inside measurement of such fields and maps them. The map or plan made for this purpose should shew the exact positions of trees, gate posts, &c., so that, to ascertain the quantities of the varying crops from year to year, it will be only necessary for him to measure distances along the fences from certain fixed points and to compute the areas in the office with a scale.

Besides the new photographic process, with which I am entirely unacquainted, and which of course can only be applied in such large departments as that of the Ordnance Survey, there are four methods generally employed for the reduction of maps.

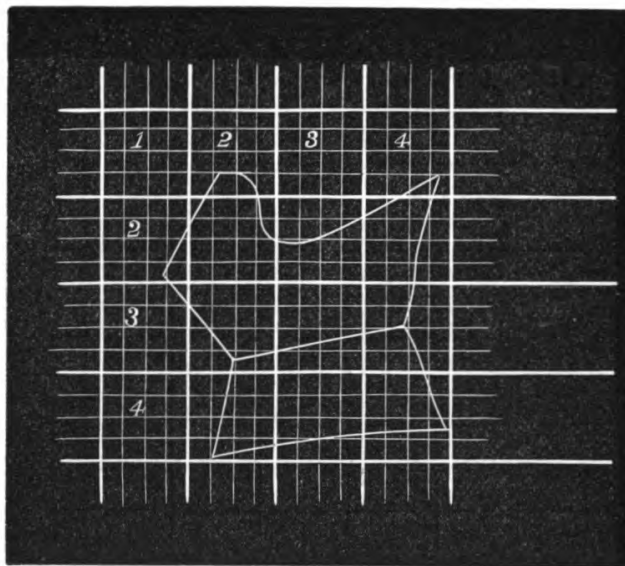

FIG. 34.

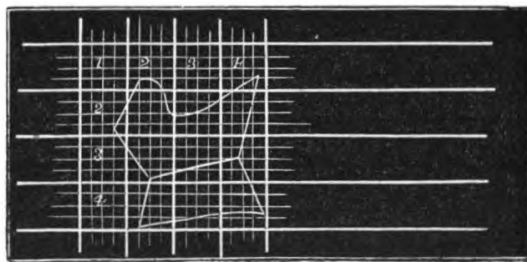

FIG. 35.

The very old and I believe up to the present time the most accurate and simple system of reducing a map is by the use of squares and proportional compasses. The squares should consist of a series of parallel lines drawn exactly according to scale one chain apart, and crossed at right angles by another series precisely similar. These squares should be drawn upon the map intended to be reduced, and upon the paper for the reduced map, those upon the latter of course being drawn to the smaller scale of the proposed reduction. It considerably facilitates matters to draw the line of every fourth parallel somewhat strong, and the other lines of the squares very fine, and to number the squares, as in Fig. 34.

The advantage of numbering the squares is not so apparent in the illustration as it is when the squares are continued to, say, a hundred.

The proportional compasses, the use of which the maker will explain, can be set so that by measuring a distance on the larger scale with one end the distance on the smaller scale will be given at the other end of the compasses. The proportional compasses also carry a graduated scale for the reduction of circles. Another method of reducing is by the use of mathematical figures which can be applied to the plan intended to be reduced, as if the latter were the actual estate, and plotted at the smaller scale as from a field book.

The pentagraph or pantagraph is the instrument generally used in surveyors' offices for the reduction of maps, and a very good instrument it is where rapidity is of more consequence than minute accuracy; when, however, the latter is indispensable the pentagraph must be put aside. The application of this instrument is very simple, and will be explained by the maker, or, perhaps better, by the

printed pamphlet which always accompanies it. Its weak points consist of a lack of rigidity which causes lines made with it to be of the kind generally known as shaky; the difficulty in obtaining a point to the pencil which shall be its centre as if it were turned in a lathe; and the liability to removal of the fulcrum. When this instrument is in true adjustment, and correctly set, the fulcrum axis, the tracer, and the pencil will be in a straight line. Before using the pentagraph in a reduction which may not be shown on the graduated scale of the instrument, the pupil will do well to reduce a rectangular figure of any convenient size, and test the reduction with a scale, because it is quite possible to set the instrument in such a manner that it will correctly reduce the horizontal line, and inaccurately dispose of the vertical one. When engaged upon the reduction of a large map likely to occupy several days, I can recommend the draughtsman to drill a hole through the fulcrum, and screw it firmly to the table with an ordinary wood screw; but before doing so he should be certain that the surface of his table is level, otherwise the axis of fulcrum will not be plumb. When the fulcrum is removed the screw-hole must be properly pegged, or at some future day the drawing pricker may pierce the paper over the hole in such a manner as to cause great annoyance.

The eidograph, I am informed by those who have used it, combines both minute accuracy and despatch; if this be the case it is unquestionably the best instrument for reducing.

By a reverse of operation plans may be enlarged; but I never recommend the enlargement of a plan with an instrument, because of the multiplicity of error attending the operation. For instance, if we reduce a plan which

---

has in it many lines nearly but not quite straight, say, from a scale of one chain to an inch to a scale of six chains to an inch, and then enlarge the reduction from six chains to an inch to one chain to an inch, all the fences formerly nearly straight will be made quite so, because at the smaller scale the slight curvatures were invisible.

---

## CHAPTER XXII.

### TO COPY A MAP—COLOURING, PENMANSHIP, &c.

To copy a map becomes a very simple matter after a little experience, although to do it accurately requires great care and nicety.

The materials required for the work are some thin tracing paper, black transfer paper, lead weights, tracing point, and the paper upon which the copy is to be made.

The black transfer paper is made by well rubbing dry powdered black lead upon one side of a sheet of tissue paper, and afterwards rubbing off the loose powder. The drawing paper must be well seasoned, as explained in Chapter XV. to prevent contraction.

The *modus operandi* is simply this:—Make a correct tracing of the map on the thin tracing paper; lay the tracing upon the drawing paper in proper position; place the black transfer paper between the two, taking care that the black side be laid downwards; place covered lead weights where they may be required to keep the papers flat upon the table; and with the tracing point press gently upon all the lines of the tracing. Now remove the tracing and transfer paper, and a true copy of the original map will appear in black lead upon the paper underneath.

In case there should be many copies of the map to make, and the original tracing should be cut to pieces by the tracing point, be particular to prepare a new tracing from the original map and not from one of the copies.



If the pupil wears a ring—and I fail to see any advantage that can accrue to him by doing so—he must be careful that it does not press upon the tracing during the operation of the transfer, otherwise he will transfer, besides the details of the map, something after the style of those horrid things often seen in nightmare, and which I believe are admitted to be beyond description.

To colour well with judiciously selected tints in a manner that shall at once be workmanlike and attractive, giving the map somewhat the appearance of a bird's eye view, is an art which can only be acquired by constant practice. When I have told you that all dwelling houses should be coloured with carmine; outbuildings with slate colour; arable lands with raw umber; roads with burnt sienna; ponds, rivers, and other waters, with Prussian blue; and woods, plantations, and pasture lands with green, I have indeed told you little.

Never attempt any kind of colouring by an artificial light or you will be a self-deceived man when daylight arrives—and particularly so if you have been employing green or yellow—and never use gall upon any pretence whatever. That gall makes the colour flow freely on a surface that may be slightly greasy, I readily admit; but in the course of time the matter contained in it is absorbed into the paper considerably beyond the limits of the colouring, giving it a dirty or greasy appearance. On the vellum tracing cloth, which is now extensively used, the gall border, as I will term it, soon shows itself and rapidly becomes a disfigurement to the work: of course this is more or less noticeable as a greater or smaller quantity of gall is employed.

Never employ chemicals for the removal of colours, or you will again be the victim of self-deception: their



employment is liable to cause the paper to decay, and colours afterwards put upon the affected part to gradually fade away. The latter might be serious in the case of a plan attached to a legal or public document, and referred to solely as being coloured green, pink, or otherwise, as the case might be.

Whatman's hand-made paper mounted on holland or linen takes colour very well : the same paper unmounted requires to be first rubbed with bread. Tracing paper, particularly that of French make, takes colour very well : tracing cloth, parchment, and vellum require to be well rubbed with india-rubber. Tracing cloth takes colour best after it has been well dried by the fire.

I prefer the colours of Messrs. Winsor and Newton to those of any other maker, and I recommend red sable brushes in preference to those of camel's hair, because they generally have a better point and possess more spring.

When a map is coloured well, every tint is quite uniform in shade and free from blotches. To colour well, never attempt to produce a deep colour—should such ever be necessary—by one operation, but with a delicate tint lay on coat after coat until the required depth of colour is obtained. Always mix sufficient colour before commencing to use it, and well stir it at every dipping of the brush. The paper to receive the colour should always be laid upon a slight inclination, so that the liquid will drain towards the brush and keep the working edge from drying. If the working edge of the colour be allowed to dry, you have failed to produce good work.

Rivers, lakes, &c., can be coloured with great effect by diminishing the depth of colour from their outer edges to their centres ; this can easily be accomplished by keeping each successive coating of colour a little within the limits

---

of the coat which immediately preceded it. Another plan of colouring rivers is by the process known as softening, which consists in quickly following a small brush dipped in dark colour with a large brush dipped in water.

Always lay on the colour as quickly as possible, and never "touch up" the work or go over it with a second coat until the first coat is quite dry.

On the head of penmanship—much as I like to see it done well—I can give no instructions likely to be of any practical utility. The pupil must obtain good copies for his guidance, and persevere in their imitation until he has equalled them.

Pattern drawings of trees, and other embellishments to a map, can easily be obtained, and must be imitated in like manner.

---

## CHAPTER XXIII.

### COMMENCEMENT OF A PARISH SURVEY—SURVEYING TO A SCALE OF FEET.

ALTHOUGH many years have elapsed since I read Captain Dawson's instructions as to the conduct of a parish survey, I have not forgotten the substance of them.

To obtain a good construction, he recommends the surveyor to set out a base-line through the longest extent of the parish; to cross such line as nearly as possible at right angles by another line extending from one side of the parish to the other side; and to connect the ends of the two lines so set out by other lines to complete the figure of a trapezium—or practically, two triangles upon a common base.

If the reader has carefully followed me, and will for a moment return to the example contained in Chap. XIII., he cannot fail to have discovered that I most fully indorse the recommendations of Captain Dawson, which I believe have withstood the test of time without amendment.

The surveyor should, if possible, as a first step, obtain a rough copy of any existing old map: this will be of immense service to him, as in all probability it will be approximately correct as to the outer boundaries, and will at once point to him the figure with which he has to deal. If he employs an assistant to conduct the survey, an old map will be particularly useful, inasmuch as he can mark upon it the lines of construction which, in his opinion are

the best : before, however, these lines can be decided upon, the parish must be carefully viewed to see that there are no formidable obstructions in the way.

For many engineering purposes, it is often advisable to prepare a plan to a scale of feet, say, for instance, to a scale of 60 feet to an inch.

To prepare a plan of this description, when the scale is smaller than 40 feet to an inch, I should make the survey with Gunter's chain in the usual manner, and plot it to a scale of chains and links which should be equal to the scale of feet required. Scales of this description can be purchased of Mr. W. F. Stanley, of Great Turnstile, Holborn, and no surveyor should be without them. When, however, the scale is as large, or larger than 40 feet to an inch, the measurements should be taken with a chain a hundred feet in length and plotted to a scale of feet. In booking measurements of feet and inches, it will be found convenient to enter them as pence and shillings, thus— $12/6$ , the latter representing 12 feet 6 inches.

---

## CHAPTER XXXIV.

### TOWN SURVEYING.

TOWN surveying is by far the most difficult and tedious branch of the profession, and in my opinion the class of surveying the least to be desired. Entering upon the survey of a town, the surveyor must make up his mind to be a patient and good-tempered man; he must be prepared to have his chain kicked aside time after time just as he has correctly laid it out for the purpose of measuring offsets therefrom; he must be prepared to withstand insults of every conceivable kind; and must be proof against the villanous smells with which he is sure to be assailed in certain districts.

I am prepared to be told by many readers that I am altogether mistaken as to bad smells; that modern sanitary legislation has done away with them; and that the inspectors of nuisances could not possibly allow them to exist. I say that although much has unquestionably been done there is still more to do, and that masses of reeking filth are much more numerous in the worst districts of a town than the gentleman residing in the best part will readily believe.

In the first place the surveyor must carefully examine the town and note its peculiarities and formation; he must carefully examine it with a view to becoming acquainted with its longest streets, its narrowest alleys, and those peculiar places through which direct lines of measurement

can be taken ; he must further examine it to see if it can be encompassed by some mathematical figure which would serve as a basis for the work to be done.

Nearly every small town can be encompassed by lines forming a triangular construction, by keeping such lines a little distance without the limits of the town ; and, whenever it is practicable, to have such a construction as a basis for further operations, I recommend it with the greatest confidence. The town of Chippenham, for instance, is a town which could well be encompassed in the figure of a triangle.

The triangulated construction being set out and measured, and the necessary stations laid down in manner hereinbefore described, the surveyor can, in many instances, measure all the details as in an ordinary survey without recourse being had to any angular instrument. When, however, he cannot get *through* lines, he must work from one outside line to another in the manner described in Chap. XIX. under the head of “transverse surveys,” allowing his first series of interior lines to traverse the principal parts of the town.

The experienced surveyor will, however, discover, by a careful search, parts of the town through which direct lines can be set out and measured that the amateur would not find. I therefore recommend the pupil to most carefully examine the town in search for places through which such lines can be measured, and not in a hurry to state that no such places can be found, or that to measure a through line is an impossibility—the latter being in my opinion a *farity*.

Lines can often be continued through the windows of houses, with the aid of a theodolite, even when such windows are upon the upper floors ; they can also often be continued through by taking the line of a high gable end as described in Chap. XIV. under the head of “lines measured on the work ;” also by a judicious selection of



certain points in one continuous line, which shall bear or be upon some such distant object as is named in Chap. IV. By means of the latter selected points, the surveyor may have the opportunity of setting out his line by both a backward and forward movement. In certain special cases lines may be continued through houses or other obstructions by a theodolite fixed upon a short stand on the top of such obstructions. I have upon two or three occasions fixed a theodolite upon the ridge of a building of ordinary height.

All that it is possible for man to write upon the several contrivances for measuring a direct line through obstructions, will not benefit the pupil so much as a practical exercise of his own ingenuity; I recommend the latter in preference to a series of lessons because knowledge so acquired is always retained.

Errors of measurement will creep into the work if the pupil be not careful in crossing walls; a plumb-line should always be used, and in many cases it will be found advisable to mark the crossings of walls with a piece of chalk.

When a town extends over an extensive area, and is surrounded by a thickly-populated neighbourhood, it will in all probability be next to an impossibility to encompass it by any figure of triangulation. Southampton, for instance, is a town, both from its size and peculiar situation, to which no surveyor could for a moment think of applying a triangulated construction, and would not attempt to survey without a good theodolite.

To survey a town of the latter description, as long a base-line as can be conveniently set out should be established in one of the longest streets, and if such street be centrally situated in the town so much the better. The theodolite must read at zero upon the line, and all other lines of the survey must be fixed by means of the bearings taken with



that instrument in manner described in Chap. XVIII. Abundance of proof to the operations will be afforded as the work proceeds by the closures of the several lines, which, in all probability, will represent a peculiar figure of network.

It will be found advantageous in the survey of either a town or any intricate work to take measurements one day, and plot them the next day. By pursuing this method mistakes are easily rectified, confusion is avoided, and the surveyor is enabled to plot quicker from having a clear recollection of the property to which the figures of his field book or field sketch refer.

Although I have stated in a former chapter that offsets should not exceed a chain in length, I think the surveyor will find it advantageous in the survey of a town, where offsets are certain to be very numerous, to set out his lines as close as possible to the work, and for this reason I advise him, unless the streets be very narrow, to have lines on both sides of them. I have found from experience that by having lines on both sides of the streets, I could make better and more rapid work than I could by having lines along their centre, because the operations would not be so much interfered with by the traffic.

When the survey of a town is extended over a considerable period, I recommend the surveyor as a first step to lay down on the paper for the plan a large and fully divided circle which will serve as a protractor throughout the work.

The advantages to be thus gained are a saving of time, and the avoidance of damage to the paper occasioned by, and errors consequent upon, the frequent removal of the circular protractor.

A further important feature in town surveying is a



---

surveyor should make an accurate tracing of it on sheets of convenient size, and carefully examine it on the ground to see that it is quite correct, and that there are no omissions. The latter work is generally done in connection with the preparation of the book of reference: in some instances when the survey is made by an assistant for valuation purposes, the principal undertakes the work of examination in connection with his duties as valuer.

As I consider town surveying quite an independent branch of the profession, and as this work is not prepared for the special guidance of those who generally undertake it, I have confined my remarks to a few brief comments on its particular characteristics, I have, nevertheless, given advice to the pupil which will be found serviceable, and appended a sketch illustrative of detail measurements.

If the town to be surveyed extend over a considerable area, and afford no position for a line of considerable length which shall act as a base to the operations, it must unquestionably be surveyed with the aid of trigonometrical observations.

---

## CHAPTER XXV.

### TESTING THE ACCURACY OF A SURVEY—GENERAL REMARKS.

THE accuracy of a map is frequently tested by the measurement of a straight line set out from one side of the survey to the other side, and by the crossings of the several fences, which should be noted in its measurement. Additional test can be afforded by a series of angles taken with a theodolite from fixed points in the line to certain conspicuous objects within the limit of the survey.

The best test, however, and the only one which I can recommend with confidence, consists in the measurement of a large triangle within the area of the survey, and the subsequent measurement of a perpendicular or tye line from its apex to its base. The entire fields in which the angular points of the triangle are contained should be carefully surveyed; the crossings of all fences, boundaries, &c., should be noted; everything within a chain of the lines should be measured; and the whole plotted upon the same scale as the map. Now if the map be correct, a tracing of the test work will fit truly upon it; if incorrect the tracing will not fit it.

When there are only a few points of difference, I advise the surveyor to carefully examine his test work, and remeasure those parts of it in which the differences exist before declaring the survey to be incorrect, because we are all equally liable to error.

Although the pupil may have gathered a fair theoretical knowledge of land surveying from a careful perusal of the foregoing pages, he must distinctly understand that he has not gained an atom of practical knowledge.

If he will follow my advice he will read and practise alternatively: by this means he will make himself slowly and surely a practical man.

To grapple with a volume of theory at one stroke is too great an undertaking, and one likely to be associated with those "little forgets" which so often prove fatal to good work.

As no surveyor has ever attained that happy state known as *perfection*, the pupil has before him a world-wide field of enterprise which I would recommend him to enter with the character of determination.

Experience alone can teach him amongst other things the best positions for his lines—the best measurements for him to take in the survey of intricate details: experience alone can make him accurate and rapid. How clearly does the hand of practice show itself upon every work! I know of no mechanical work, of an ordinary character, upon which experience, and the hand of practice show themselves so clearly as upon the working map of a surveyor: on the other hand, lack of nicety, good construction, and finish, and the addition of the erasures employed to get rid of bungling operations as clearly point out the work of the amateur or dabbler.

The over-zealous pupil is also liable to bungling operations, for, with both heart and mind intent upon the work, he is certain from want of experience to take a quantity of measurements by no means necessary, and to disfigure the paper by a series of useless pricker holes referring thereto.

The mistakes common to the beginner are, taking offsets

from a chain which is not laid truly in the line, and taking those which from the size of the scale cannot be plotted, and are consequently unnecessary ; making stations a little out of the line which will afterwards affect the lengths of other lines to be produced through them ; taking offsets to buildings which have projecting courses above the projections instead of below them and close to the ground ; taking offsets at various other angles from the chain than a right angle, and setting out a crooked line in lieu of a straight one.

A good surveyor will, upon an average, complete the survey of forty acres per day of ordinary field or parish work.

As customary measurement is fast upon the wane, I have considered the mere mention of it quite sufficient. Copies of the old tables for its conversion into statutory measurement can still be obtained, but I feel almost certain my readers will never require to see them.

In arranging this work it has been my endeavour, in the simplest language, and in the simplest and most concise manner, to impart to the reader a good plain practical knowledge of the profession of a land surveyor. Whenever it comes into the hands of a professional surveyor, I trust he will do me a kindness by reading it and suggesting to me anything which, in his opinion, would be an improvement or useful addition.

As a study of surveying is useful as an advance towards the higher branches of engineering, and as it tends to acquaint the pupil with construction, a knowledge of which is essential to all branches of mechanical work, the ulterior advantages that may be gained from a perusal of these pages should not be lost sight of.

---



## CHAPTER XXVI.

### IN MEMORY OF THE PAST.

My honest conviction is, that a class of persons numerous to be found in the civilised world is the discontented class: the class whose sole activity is devoted to grumbling at its station and lot: the class that is always envious of the successes of others. Many a time have I heard a surveyor exclaim, "Oh, if I were only a doctor!" and the doctor, "Oh, if I were only a surveyor!"—the former complaining of his tedious labours in the field; the latter regretting that his labours are out of the field.

And what is the occasion of these exclamations and regrets? What can it be that now makes the man rebel against the choice of his youth—the profession into the ranks of which he so proudly entered—the profession to which he was trained by the exertion and self sacrifice of parents whose hopes were that he might rise and do honour to the family name? The answer is plain. Discontentment, idleness, or ingratitude.

Be grateful, my friends, for all that in youthful and prosperous times has been done for you; look forward as to a brighter prospect and a better end; but never forget the kindness and consideration of the past. The course through the world, like the career of true love, never runs smooth; therefore, inasmuch as it is a pleasure to think of past kindnesses, let it be a pleasure to endeavour to



forget those matters which may have been troublesome for the time. Contentment is a fortune in itself: perseverance its hand-in-hand companion.

As to my past professional career, it affords me quite a joyous recollection, as I look with pleasure upon difficulties satisfactorily overcome, and with pride upon the profession that has placed before me scenes I could never have looked upon, and introduced me into society I should never have known, without it. It gives me pleasure to say that I am now as much attached to it as I ever was; aye, as much as I was when I completed my first survey of the "difficult field."

As the circle of my vision embraces for the moment an apparent facsimile of the huge pile of time-honoured maps and field books once my handiwork, the faces of good old friends and true are recalled to memory, which further carries me back to the very beginning; to days when kindness surrounded me—to days when many friends, now not, were giving me the benefit of their past experiences.

On the other side of the picture, my memory reverts to a happy recollection of the many adventures and enjoyments that have associated themselves with my peregrinations; and I venture to say, that if truth could replace fiction, the adventures of your humble servant during his career as a surveyor, would be quite a parallel to those of any Roderick Random.

I have another pleasure to record: it consists in a recollection of the underserved and unrequited kindnesses, I have at all times received at the hands of strangers,—it further consists in the discharge of a duty I owe (not Pecksniffianly to society) but to the many surveyors under whom I have acted, by thanking them for the gleanings

---

I have from time to time gathered from their successful harvestings.

And now, my friends, a few parting words and, for the present, adieu. I hope the time is not far distant when you will hear from me again, and that meanwhile these pages will keep our friendship together.

Have confidence in yourselves and remember—

Self-dependent power can time defy,  
As rocks resist the billows and the sky.

---



# INDEX.

---

	<b>A.</b>	
Adjustment of the chain	... ..	page 5
Adjustment of the tape	... ..	5
Allotments, to set out	... ..	60—63
Angles and bearings	... ..	64—69
Areas computed	... ..	29—33, 40—42
	<b>B.</b>	
Bearings	... ..	64—69
Boundaries	... ..	8, 9, 38
Box sextant	... ..	16
Building plots	... ..	60—63
	<b>C.</b>	
Circle, area of	... ..	32
Cleanliness	... ..	54, 55
Clearing for lines in woodlands	... ..	12
Colouring a map	... ..	83—85
Computation of areas	... ..	29—33
Conversion of feet into links	... ..	5
Conversion of links into feet	... ..	4
Copying a map	... ..	82, 83
Cross staff	... ..	17
	<b>D.</b>	
Decimals of an acre and their equivalents	... ..	32
Detached buildings	... ..	48
Ditches	... ..	62

Division of land	... ..	page 57—59
Division of the circle	... ..	16
Drawing paper	... ..	55
<b>E.</b>		
Eidograph	... ..	80
Enlarging scale of map	... ..	80, 81
Equalising a boundary	... ..	38
<b>F.</b>		
Field book, example of	... ..	45, 46
Figures suitable for chain survey	... ..	6
Forgetfulness, to avoid	... ..	1
Frontage measurement	... ..	63
<b>G.</b>		
General remarks...	... ..	95, 96
Growing crops	... ..	77
<b>H.</b>		
Horizontal measurement	... ..	22—26
<b>I.</b>		
Inaccessible distances	... ..	17, 18, 19
Inking in	... ..	56
Irregular figures	... ..	34—37
<b>L.</b>		
Land chain adjusted	... ..	5
Land chain and its peculiarities	... ..	4
Light Papers	... ..	14
Limits to area to be properly defined	... ..	47, 48
Lines measured on the work	... ..	49
Lines set out by the eye	... ..	10, 11
Lines set out on hilly ground	... ..	14, 15
Lines set out with theodolite	... ..	20, 31
<b>M.</b>		
Measurement of highly valuable property with 10ft. rod	... ..	5
Measurement of inaccessible distances	... ..	17, 18, 19
Measurement of single irregular figures...	... ..	34—37

Measurement of several fields together ... ..	page 43—46
Measurement of frontages ... ..	63
Measurement of superstructures ... ..	75, 76
Measurement of growing crops ... ..	77
Measuring a line ... ..	27
Memory of the past ... ..	97
O.	
Obstructions in lines... ..	12, 13
Offsets and offset staff ... ..	27, 28
Optical square ... ..	17
Outfit for a Surveyor... ..	1
P.	
Paper, management of ... ..	54
Paper scale ... ..	54
Parish survey ... ..	86—87
Penmanship ... ..	85
Pentagraph... ..	79
Plotting ... ..	53
Position of plan... ..	54
Practice of land surveying ... ..	1
Problematical proofs ... ..	29
Proportional compasses ... ..	79
Protractor, the use and adjustment of ... ..	64—67
Q.	
Quality lines ... ..	75
R.	
Reducing board ... ..	23
Reducing scale of maps ... ..	77—80
Reduction of hilly to horizontal measurement ... ..	22—26
Reference numbers ... ..	47
Right angle set out by measurement ... ..	34
Rivers to measure across ... ..	17, 18, 19
S.	
Scale of feet ... ..	87
Stakes, to drive, properly ... ..	57, 58
Standard measure for testing chain ... ..	5





# LIST OF BOOKS

PUBLISHED BY

HORACE COX,

"THE FIELD" OFFICE, 346, STRAND, LONDON, W.C.

\*\*\* Orders for any of the following works, with postage stamps or post-office order for the amount, should be sent to MR. HORACE COX, Publisher, 346, Strand, W.C., or they may be obtained by order of any bookseller.

Second Edition, Enlarged, 25s., by post, 1s. 4d. extra.

**A MANUAL OF YACHT and BOAT SAILING.** By DIXON KEMP, A.I.N.A., Author of "Yacht Designing." This work contains exhaustive information upon the subjects of Yacht and Boat Sailing and Boat Building, and is profusely illustrated. Super-royal 8vo., with full-page Drawings.

The favour accorded to the First Edition of the "Manual of Yacht and Boat Sailing," and its rapid Sale, justify the belief that the useful character claimed for its information was warranted.

In the New Edition the sphere of this information has been much enlarged.

Among the additions to the book will be found lines of the celebrated yawl JULLANAR; lines of 10 and 5 tonners, including the lines of FREDA and LORELEI; lines of the Sailing Boats of the Irish Model Yacht Club; lines of the last NAUTILUS and PEARL Canoes, Clyde Canoes, Cruising Canoes, &c.

The Appendix of General Information has been largely added to, with a view of widening its usefulness.

The New Edition is about one-third larger than the first, and an addition to the price has of necessity been made.

- I.—Gives in a popular manner instruction as to the Displacement, Buoyancy, and Stability of Yachts and Boats.
- II.—Lateral Resistance.
- III.—Centre of Effort and Propulsion by Sails.
- IV.—The Action of the Rudder and Steering Efficiency.
- V.—Sail-carrying Power and Speed.
- VI.—Resistance and Speed, and the Influence of Thames Measurement.
- VII.—Ballast.
- VIII.—Spars. Rules for determining the length, girth, placing, &c., of spars.
- IX. } Selecting a Yacht, Examining a Yacht
- X. } before Purchase, Building a Yacht,
- XI. } Tables of Scantlings, &c.
- XII.—Equipment of a Yacht, including complete information as to blocks, rigging, &c.
- XIII.—Seamanship.  
This chapter contains complete information as to the Making and Taking In Sail, Sailing by the Wind, Sailing by the Wind in a Heavy Sea, Off the Wind, Running before the Wind, Tacking, Gybing, Lying To, Anchoring, Getting Under Way, &c. It also gives complete information as to the Management and Sailing of Open Boats.
- XIV.—The General Management of a Yacht, including Duty and Discipline of the Crew.
- XV.—Yacht Racing.  
This chapter contains information as to the expenses of yacht racing, and an exposition of Yacht Racing Rules.
- XVI.—Centre-board Boats, their history and general form; Boat Sails.  
This chapter includes designs for Centre-board Boats for Rowing and Sailing. The sec-

tion on Boat Sails gives varieties, with working drawings of the Balance Lug, Chinese Lug, Sprit Sails, Gunter Sprit Sails, Falmouth Luggers, Lateen Sails, &c.

- XVII.—Brighton Beach Boats, with designs.
- XVIII.—Centre-board Sloop, with designs.
- XIX.—Una Boats, with designs of the original Una and a Cowes Una.
- XX.—New Brighton Beach Boats, with designs.
- XXI.—Windermere Yachts, with designs.
- XXII.—Itchen Boats, with designs of Wild Rose, Centipede, &c., and design of Itchen Punt.
- XXIII.—Clyde Sailing Boats, with designs.
- XXIV.—Yachts of Five and Ten Tons, with lines of Freda and Lorelei.
- XXV.—Lough Erne Yachts, with design of the Witch.
- XXVI.—Irish Model Yachts, with design of Heathen Chinee.
- XXVII.—Penance Luggers, the Coble, Galway Hooker and Pookhaun, and Norwegian Pilot Boats, &c.
- XXVIII.—The Jullanar, with design.
- XXIX.—Double Boats, with design.
- XXX.—Ice Yachting, with design.
- XXXI.—The Nautilus Canoe, Cruising Canoes with three designs; Clyde Canoes with designs; and designs of the Racing Canoes Nautilus, 1878, Pearl, 1879 and 1880.

Appendix. Contains complete instruction as to Practical Boat Building.

This section is arranged Alphabetically in the form of a Dictionary and embodies a variety of information connected with Yachts, Boats, &c.

Full instruction is given as to the building and management of every boat described.

WORKS PUBLISHED BY HORACE COX.

Price £3 3s., in Imperial folio.

# YACHT DESIGNING.

By DIXON KEMP.

ASSOCIATE INSTITUTE NAVAL ARCHITECTS.

**T**HIS WORK has been compiled to give information upon the practical application of the scientific principles upon which the art of Yacht Designing is based. A complete system of construction is provided for the guidance of the inexperienced, together with all necessary information relative to the primary subjects of buoyancy, stability, resistance, and speed.

The text is amply illustrated by diagrams, and a very valuable collection of plates of the lines of about thirty celebrated racing yachts of the period, including such small craft as 10-tonners, 5-tonners, sailing boats, boats for rowing and sailing, and sailing canoes. Some of these plates are nearly 4ft. in length, and all are on scales adapted for working drawings.

Every calculation which it is necessary to make in determining the value of a design, or the elements of a vessel, are given in detail, and the rules by which such calculations are made are sufficiently explained to render their application easy by the inexperienced.

THE CONTENTS OF THE WORK ARE AS UNDER :

- Chap. I. Explanation of Principles.  
II. Description of Various Rules and Formulæ of Use in determining the Qualities of a Yacht.  
III. Application of the Foregoing Rules.  
IV. Calculation of the Stability of a Yacht.  
V. The Effect of Shifting and Removing Weights on Stability—The Longitudinal Meta-centre—Alteration of Trim—Pitching and Scending and Rolling.  
VI. Power to Carry Sail—The Impulse of the Wind as a Propelling Power—Table of Velocity and Pressure of Winds.  
VII. Resistance to Vessels moving in Water—Stream Lines—The Wave-line Theory—Relative Lengths of Fore-body and After-body for Speed in Knots per Hour.  
VIII. Surface Friction—Calculation of the Immersed Surface—The Immersed Surface in Relation to Lateral Resistance.  
IX. Value of the Wave-line Theory—The Fore-body—The After-body—Form Area, and Position of the Midship Section.  
X. Nystrom's System of Parabolic Construction.  
XI. Calculation of Probable Speed.  
XII. Construction Drawing.  
XIII. Laying off—Taking Off.  
XIV. Ballast and Spars.  
XV. Resistance Experiments with Models, whereby the Resistance of the Yacht from that of the Model can be calculated.

**SPORTING SKETCHES with PEN and PENCIL.** By FRANCIS FRANCIS and A. W. COOPER. Demy 4to., with 12 full-page illustrations, some of which contain Portraits of Sporting Celebrities, and 24 vignettes. Price 1*l.* 1*s.*

CONTENTS.

The First of September.	Rabbit Shooting.
A Day in a Punt.	Roaching.
Mark Cock!	Grouse Shooting.
Trouting.	Salmon Fishing.
Long Tails and Short Ones.	Snipe Shooting.
Paying the Pike.	Grayling Fishing.

**THE DIAMOND DIGGINGS OF SOUTH AFRICA:** a Personal and Practical Account. By CHARLES A. PAYTON, "SARCELLE," of "The Field." With a Brief Notice of THE NEW GOLD FIELDS. With Maps, large post 8vo., price 6*s.*; post free, 6*s.* 5*d.*

**HOT-POT.** Miscellaneous Papers by FRANCIS FRANCIS  
Post 8vo., in cloth, price 5*s.*

WORKS PUBLISHED BY HORACE COX.

Recently published, price 21s., by post, 9d. extra, with full-page Illustrations, and Folding Plates.

**MODERN WILDFOWLING.** By "WILDFOWLER."

Frontispiece Illustration (folding plate), "Wildfowler" and Puntsman in his Double-handed Punt.

CONTENTS.—Muzzle-loading and Breech-loading Punt Guns (with full-page illustrations); the "Setting" of Punt Guns; Rope Breechings and other Recoil Apparatus (with illustrations); Ancient and Modern Punts (with several full-page and folding plates, plans, and illustrations, measurements, &c., including those of "Wildfowler's" double-handed punt); Launching Punts and Canoes; Punting by Day and by Night; Coot Shooting in France; Modern Full-choked 4-bores, 8-bores, 10-bores, and 12-bores for Wildfowl Shooting; Flapper Shooting (illustrated); Inland Duck Shooting; Sailing to Fowl (illustrated); Decoying to the Gun (illustrated); Decoying in America (illustrated); American Decoys (illustrated); American Blinds (illustrated); Shore Shooting; Flighting; Stalking Horse (illustrated); Wildfowl and Seafowl Acts, Close Times, Laws, &c.; "Wildfowler's" Table of Loads; Netting Plovers and Snipe Snaring; Hooking and Snaring Seafowl; Decoying into the "Pipes;" Flight Ponds and Rock Fowling; Concluding Remarks.

**The ENGLISH GAME of CRICKET: comprising a Digest**

of its Origin, Character, History, and Progress, together with an Exposition of its Laws and Language. By CHARLES BOX, author of "The Cricketers' Manual," "Reminiscences of Celebrated Players," Essays on the Game, "Songs and Poems," "Theory and Practice of Cricket," &c. 4to., bevelled boards, gilt edges (500 pages), with appropriate illustrations, price One Guinea; by post 22s. 3d.

**THE ANNALS of TENNIS.** By JULIAN MARSHALL.

The work will be found very complete, and, it is thought, justly entitled to take its place as the standard work on Tennis. It has cost its author much laborious research; and, independently of its great value to tennis players and all lovers of the game, it is trusted, from the vast amount of curious lore it contains, the volume will be found not unworthy of a place on the shelves of the scholar. The author, himself a well-known amateur, is fully competent to speak with authority on the game, having had the opportunity of studying the play of the best Continental, in addition to that of the best English, masters, and, therefore, may be taken as a safe guide by learners. Crown 4to., printed on toned paper, price 25s.

Part I., price 2s. 6d.

**THE HUNTING COUNTRIES of ENGLAND: their**

Facilities of Access, Requirements, &c. By BROOKSBY, Containing:

The Belvoir.	The Quorn.
The South Wold.	The Cottesmore.
The Brocklesby.	The Puckeridge.
The Burton and the Blankney,	The Old Berkeley.
The Fitzwilliam.	

Now ready, price 2s. 6d., free by post 2s. 7d., Part II. of

**THE HUNTING COUNTRIES of ENGLAND: their**

Facilities, Character, and Requirements. A Guide to Hunting Men. By BROOKSBY.

This Part contains the following Hunts:

The North Warwickshire.	The South Nottinghamshire.
The Pytchley.	The East Kent.
The Woodland Pytchley.	The Tickham.
The Atherstone.	The Vine.
The Billesdon or South Quorn.	The South Berkshire.
The Meynell.	Mr Garth's.
The Bicester and Warden Hill Hunt.	The H. H.
The Heythrop.	The Tedworth.
The Old Berkshire.	Lord Ferrers'.
The South Oxfordshire.	The Warwickshire.

Parts I. and II. can be had bound together, price 4s. 6d., by post 4s. 8d.

**THE "FIELD" HUNTING MAP, Printed in Colours,**

giving the Names and Districts of each Pack of Hounds from Carlisle to Land's End, in one Map, bound in red cloth, mounted on canvas, size 25in. by 25in., price 4s. 6d.; by post, 4s. 8d.

WORKS PUBLISHED BY HORACE COX.

Second Edition, in the press.

**PHEASANTS for COVERTS and AVIARIES: their Natural History and Practical Management.** By W. B. TEGETMEIER, F.Z.S., author of "The Poultry Book," "Pigeons," "The Homing Pigeon;" Editor of the Poultry Department of "The Field," &c. Illustrated with numerous full-page Engravings drawn from life by T. W. Wood. Royal 4to., bevelled boards, gilt edges, price 12s. 6d.

**THE CATTLE OF GREAT BRITAIN: their History, Management, &c.** Edited by J. COLEMAN. Price 18s., in imperial 4to., bevelled boards, gilt edges, with eighteen full-page engravings by Harrison Weir, toned paper, illustrating each Breed of Cattle.

PART I.—Breeding and General Management; Principles of Feeding—Nature and Value of Different Kinds of Food; Buildings, and the Manufacture of Manure; Dairy Management, the Milk Trade, &c.

PART II.—THE BREEDS OF CATTLE:—Shorthorns, by J. Thornton; Herefords, by T. Duckham; Devons, by Capt. Tanner Davey; Longhorns, by Gilbert Murray; Sussex Cattle, by A. Heasman; Norfolk and Suffolk Red Polled Cattle, by T. Fulcher; Polled Galloways, by Gilbert Murray; Polled Angus or Aberdeenshire; The Ayrshire Breed, by Gilbert Murray; West Highland Cattle, by John Robertson; The Glamorgan, Pembrokehire or Castlemartin, and Anglesea Breeds, by Morgan Evans; The Kerry Breed, by R. O. Pringle; The Alderney, Guernsey, and Breton Breeds, by J. C. W. Douglas and others.

**The SHEEP and PIGS of GREAT BRITAIN: their History, Management, &c.** Edited by J. COLEMAN. Price 18s., in imperial 4to., bevelled boards, gilt edges, with numerous full-page engravings by Harrison Weir, toned paper, illustrating the various breeds of Sheep and Pigs.

PART I.—General Management of Sheep; Preparations for Lambing; from Birth to Weaning; from Weaning to Market; on Wool.

PART II.—THE BREEDS OF SHEEP:—Leicesters, by the Editor; Border Leicesters, by John Usher; Cotswolds, by the Editor; Long-wooled Lincoln; Devon Longwools, by J. Darby; Romney Marsh and Southdowns, by the Editor; Hampshire or West Country Downs, by E. P. Squarey; Shropshires, by the Editor; Oxford Downs, by Messrs. Druce and Hobbs; Roscommon, by R. O. Pringle; Negrette Merino; Exmoor, Black-faced or Scotch Mountain Sheep; Cheviots, by John Usher; Dorset Horned Sheep, by John Darby; Welsh Breeds, by Morgan Evans; Herdwick Sheep, by H. A. Spedding.

PART III.—Sheep Farming in Queensland, by John Sidney.

PART IV.—General Management of Pigs; The Berkshire, Black Suffolk, Black Dorset, Large White, Small White, and Middle White Breeds.

**The KENNEL CLUB STUD BOOK, Vol. I., from 1859 to 1873.**

Containing a complete record of Dog Shows and Field Trials, with Pedigrees of 4000 of the principal Sporting and Non-sporting Dogs. Edited by F. C. S. PEARCE. Now ready, in 8vo., pp. 620, price 12s. 6d., by post 13s. 4d.

VOL. II., containing a complete record of Dog Shows and Field Trials, with Pedigrees of Sporting and Non-sporting Dogs, for 1874. Price 10s. 6d., by post 10s. 10d.

VOL. III., containing a complete record of Dog Shows and Field Trials, with Pedigrees of Sporting and Non-sporting Dogs for 1875. Price 10s. 6d., by post 10s. 10d.

VOL. IV., containing a complete record of Dog Shows and Field Trials, with Pedigrees of Sporting and Non-sporting Dogs, for 1876. Price 10s. 6d., by post 10s. 10d.

VOL. V., containing a complete record of Dog Shows and Field Trials, with Pedigrees of Sporting and Non-sporting Dogs, for 1877. Price 10s. 6d., by post 10s. 10d.

VOL. VI., containing a complete record of Dog Shows and Field Trials, with Pedigrees of Sporting and Non-sporting Dogs for 1878. Price 10s. 6d., by post 10s. 10d.

VOL. VII., containing a complete record of Dog Shows and Field Trials, with Pedigrees of Sporting and Non-sporting Dogs for 1879. Price 10s. 6d., by post 10s. 10d.

**THE COURSING CALENDAR AND REVIEW.** Edited by "STONEHENGE." Published half-yearly. Fcap. 8vo., price 10s. 6d. cloth; post free 10s. 10d.

**THE STABLE: being Part III. of the Second Edition of the FARM, GARDEN, STABLE, and AVIARY.** Large post 8vo., price 5s.; post free, 5s. 3d.

**THE RURAL ALMANAC and SPORTSMAN'S ILLUSTRATED CALENDAR.** Its contents comprise Information of the greatest utility and interest to the Sportsman and Country Gentleman. Illustrated. Published annually. Price 1s.; by post, 1s. 2d.



WORKS PUBLISHED BY HORACE COX.

**The DOGS of the BRITISH ISLANDS.** Edited by "STONEHENGE" (with the aid of several experienced breeders). **THIRD EDITION.** Completely re-written, with new full-page engravings. In one volume, bevelled boards, gilt edges, price 15s., by post 15s. 11d.,

Also in parts, as follows:

**PART I.**—Book I. Management of Dogs in Health; Book II. Drugs commonly used for the Diseases of Dogs and their Modes of Administration; Book III. The Ordinary Diseases of the Dog, and their treatment; Book IV. Judging at Dog Shows and Field Trials.

**PART II.**—**DOGS USED IN SPORT.**—Book I. Dogs Used with the Gun; Book II. Hounds and their Allies.

**PART III.**—**NON-SPORTING DOGS.**—Book I. Watch Dogs; Book II. Sheep and Cattle Dogs; Book III. Terriers; Book IV. Toy Dogs; Appendix.

**THE ROWING ALMANACK and OARSMAN'S COMPANION,** 1881, contains: A Calendar with Space for Memoranda, and High Water Table, with a Table of Tidal Observations; Record of all Regattas and principal Club Races in 1880, with a copious Index; a Review of the Rowing Season of 1880; an Itinerary of the River Thames from Oxford to Putney, showing all the points of interest, with Hotels, &c.; a Rowing Directory; the Lengths of the different Racing Courses; the Laws of Boat Racing; the Rule of the Road on the River; and Tables of Winners of all the principal Races and Regattas; together with Advertisements from Riverside Hotel Keepers and Boat Builders. Price 1s., by post 1s. 1d.

**MOORE'S COLUMBARIUM,** Reprinted verbatim et literatim from the exceedingly rare original edition of 1735, with some recently discovered particulars respecting the Author. By W. B. TEGETMEIER, F.Z.S. Price 2s. 6d. by post, 2s. 8d.

**PRACTICAL FALCONRY;** to which is added, **HOW I BECAME A FALCONER.** Vol. VII. of "THE FIELD" LIBRARY. By GAGE EARLE FREEMAN, M.A. ("Peregrine," of "THE FIELD"). Price 5s. cloth; post free, 5s. 3d.

**THE FIELD DUPLICATE JUDGING BOOK** facilitates the work of the Judges at Poultry and other Shows, by a very simple method of entering and preserving a duplicate judging list. Price 6d.; or 2s. 6d. the half-dozen; by post, 5d. extra.

**THE QUEEN LACE BOOK: an Historical and Descriptive** Account of the Hand-made Antique Laces of all Countries. By L. W. Price 5s., 4to., printed on toned paper, with plates; post free, 5s. 4d.

**PART I.—MEDIÆVAL LACEWORK AND POINT LACE.** With thirty illustrations of Lace Specimens, and seven diagrams of Lace Stitches. This part contains the whole of the series of articles on Antique Point Lace which have been published in "The Queen." The pamphlet will prove an invaluable guide and book of reference to ladies interested in Antique Lace, and, with its highly ornamental embossed cover, will form a handsome ornament for the drawing-room table.

**MOSS FROM A ROLLING STONE; or Moorish Wanderings** and Rambling Reminiscences. By CHARLES A. PAYTON, "SARCELLE," of "The Field," "The Country," &c. Author of "The Diamond Diggings of South Africa." Post 8vo., price 7s. 6d.

**THE IDSTONE PAPERS.** A Series of Articles and Desultory Observations on Sport and Things in general. By "IDSTONE." Second Edition. Large post 8vo. price 7s. 6d.; post free, 7s. 11d.

**THE BARB and the BRIDLE: a Handbook of Equitation** for Ladies, and Manual of Instruction in the Science of Riding, from the preparatory suppling exercises on foot to the form in which a lady should ride to hounds. By "VIEILLE MOUSTACHE." Post 8vo., price 5s.; post free, 5s. 5d.

**ANGLING.** By FRANCIS FRANCIS. Author of "A Book on Angling," &c. Its contents are Bottom Fishing, Mid-Water Fishing, Surface or Fly Fishing, Trout Fishing with Bait, Fly Fishing for Trout, List of Trout Flies, Grayling Fishing, Salmon Fishing, Salmon Flies, On Tackle Making. Price 5s., by post 5s. 3d.

WORKS PUBLISHED BY HORACE COX.

**MANURES: their Respective Merits from an Economical Point of View.** By A. W. CREWS. Author of "Guano; its Origin, History, and Virtues," &c. Crown 8vo., price 2s. 6d., by post, 2s. 8d.

**THE POTATO and its Cultivation.** By A. W. CREWS. Price 2s., by post, 2s. 2d. In this little treatise much care has been bestowed in expounding ideas which may be followed with indubitable success.

**THE WILD BIRDS PROTECTION ACT, 1880, with comments on the respective sections, explanatory of their bearing as regards owners and occupiers of land, sportsmen, bird catchers, bird dealers, &c.; together with Notes on the Birds named in the Schedule, their provincial names, &c.** Price 1s., by post, 1s. 1d.

**THE GROUND GAME ACT, 1880, with Explanatory Notes, indicating the various periods at which the law comes into force under different conditions, its effect on existing contracts between owners and occupiers of land, and the lessees of sporting rights, the limitations placed upon the killing and selling of ground game, and other matters included in the Act.** Second Edition, price 1s., by post, 1s. 1d.

**"THE QUEEN" RECIPES.** By "The G. C.," Author of "Round the Table." VEGETABLES. Price 6d., by post, 7d.

**TABLE of LOADS for SHOULDER GUNS of All Sizes (Cylinder and Choke-bore), and Punt Guns.** By "WILDFOWLER." In small pocket form, price 6d., by post, 7d.

**THE REVISED RULES of LAWN TENNIS, as adopted by the Marylebone Cricket Club and the All-England Croquet and Lawn Tennis Club.** Price 6d.; by post 7d.

**THE FARM: being Part I. of the Second Edition of "The Farm, Garden, Stable, and Aviary." Valuable to country gentlemen, farmers, &c.** Vol. III. of "THE FIELD" LIBRARY. Large post 8vo., price 5s. cloth; post free, 5s. 4d.

**THE GARDEN: being Part II. of the Second Edition of "The Farm, Garden, Stable, and Aviary." Vol. III. of "THE FIELD" LIBRARY.** Large post 8vo., price 5s. cloth; post free, 5s. 4d.

**The REPORT of the "FIELD" TRIAL of EXPLOSIVES, GUNS, &c., held at Wimbledon, in 1878.** Compiled from the "Field" of April 29 to May 25. The handbook is printed in large quarto form that the table of results may be easily referred to and compared. 4to., price 1s.

Reprinted and Revised by Permission.

**The RULES of PIGEON SHOOTING.** Published by Special Permission, the Hurlingham Club and the Gun Club Rules of Pigeon Shooting. Bound together in cloth, gilt edges, price 6d., by post, 7d.

**MODERN ATHLETICS.** By H. F. WILKINSON, of the Amateur and London Athletic Clubs. Fourth Edition, revised and corrected. Contents: I. Ancient Athletics. II. The Rise and Progress of Modern Athletics. III. The Management of Athletic Meetings. IV. Training. V. Walking. VI. Running. VII. Jumping. VIII. Throwing the Hammer, and Putting the Weight. IX. The Laws of Athletics. X. Statistics. XI. The Best Performances on Record. Price 1s. 6d., by post 1s. 8d.

**A SYSTEM of FIGURE SKATING.** By H. E. VANDERVELL and T. MAXWELL WITHAM. The Third Edition of this, the acknowledged text-book of Figure Skaters, contains all the New Club Figures, Grape Vines, &c., as well as Instruction for acquiring Figure Skating on Rollers. Price 7s. 6d., by post, 7s. 10d.

**THE ART of SKATING; with Illustrations, Diagrams, and Plain Directions for the Acquirement of the most Difficult and Graceful Movements.** By GEORGE ANDERSON ("CYCLOS"), Vice-President of the Crystal Palace Skating Club, for many years President of the Glasgow Skating Club. Fourth Edition. In post 8vo., limp cloth, price 2s. 6d., post free 2s. 8d.

**ESTATE MANAGEMENT. A Practical Handbook for** Landlords, Stewards, and Pupils, with a Legal Supplement by a Barrister. Also Tenant Right from a Landlord's Point of View. By CHARLES E. CURTIS. Price 10s. 6d., by post, 11s.

**SHIFTS and EXPEDIENTS of CAMP LIFE, TRAVEL,** and EXPLORATION. By W. B. LORD, Royal Artillery, and T. BAINES, F.R.G.S. The work is written expressly for the use of Military and Naval Officers, Missionaries, Travellers, and any who may be obliged to "rough it" in Foreign and Savage Countries; and it is believed that the "Shifts and Expedients" here gathered together will be found of the greatest service to all such. The work contains above 700 pages, and nearly 400 Illustrations. New and cheaper Edition, with additions. Price 30s., cloth gilt.

**THE GUN TRIAL of 1879. The "FIELD" TRIAL of 12,** 16, and 20-bore GUNS, 1879; with Full Scores of the Shooting, and a Description and Woodcuts of the Force Gauge and Machine Rest used; compiled from Reports and Articles published in the "Field." Also an Appendix, containing Correspondence on Large and Small Bores, the Detonation of Gunpowders and other Explosives, Experiments on the Velocity and the Striking Force of Shot, &c. Price 1s.; by post, 1s. 2d.

**THE ITALIAN SYSTEM of BEE KEEPING; being an** Exposition of Don Giotto Ulivi's Economical Frame Hives and Honey Extractor By ARTHUR J. DANYELL, late Capt. H.M. 31st Regiment. With Illustrations. Price 1s. This pamphlet contains practical directions for the making and utilisation of frame hives, costing less than 2s. each, and a centrifugal honey extractor costing 5s. or 6s.

**OUR COMMON INSECTS: First Steps to Entomology.** By Mrs. E. W. COX. Second Edition. Price 2s. 6d.; by post, 2s. 8d.

**POPULAR ILLUSTRATIONS of the LOWER FORMS** OF LIFE. Illustrated. Vol. V. of "THE FIELD" LIBRARY. By C. R. BREE, M.D., F.L.S., F.Z.S. Large post 8vo., price 5s. cloth; post free, 5s. 3d.

**THE FIELD "LAWN TENNIS" UMPIRES' SCORE-**SHEET BOOK (with Instructions for the use of Umpires). Adapted for the use of Umpires and Players, as used at the Championship Meetings. Price 6d.; by post, 7d.

**COLORADO: its Agriculture, Stockfeeding, Scenery, and** Shooting. By S. NUGENT TOWNSHEND, J.P. (St. KAMES.) In limp cloth, price 2s. 6d.; by post, 2s. 8d.

**OUR BOATING TRIP from BORDEAUX to PARIS:** Being an Account of an Autumn Tour through France. By JAMES POWELL. Price 1s. in paper; 1s. 6d. in cloth.

**SKETCHES of LIFE, SCENERY, and SPORT in NORWAY.** Vol. VIII. of "THE FIELD" LIBRARY. By the Rev. M. R. BARNARD, B.A. The work is admirably adapted for use as a Sporting Tourist's Handbook, while it is of absorbing interest to the general reader. Price 6s. 6d.; post free, 6s. 10d.

**BOAT-RACING; or, the Arts of Rowing and Training.** By E. D. BRICKWOOD. Containing the history of racing boats and the sliding seat, instructions on rowing, coaching, and steering; the organisation and administration of boat clubs; the modern system of training for races; the qualifications of amateurs; together with historical records of boating from the earliest times to the present date; and the new laws of boat-racing; thus forming a complete manual. Now ready, price 5s., by post 5s. 4d.

**RAMBLES AFTER SPORT; or, Travels and Adventures** in the Americas and at Home. By "OLIVER NORTH." Contents—A Week's Duck Shooting at Poole, That Sheldrake, Quail Shooting in California, Bear Hunting in Mexico, Bear Shooting in California, My First Elk, My Last Bear, Round Cape Horn, Valparaiso, Santiago; Shooting in Chile, Andacollo, Lima, Panama, Jamaica; Country Sports and Life in Chile, Two Days' Fishing in Chile, "Toling" for Ducks in California, Up the Sacramento, the White Elk of Astoria, Sport in the Coast Range Mountains. Large post 8vo., price 6s.; post free, 6s. 4d.



WORKS PUBLISHED BY HORACE COX.

- A MANUAL of the LAW of SALMON FISHERIES in ENGLAND and WALES, with a copious Index.** By SPENCER WALPOLE, one of Her Majesty's Inspectors of Salmon Fisheries. Price 2s. 6d., by post 2s. 8d.
- FACTS and USEFUL HINTS relating to FISHING and SHOOTING;** being a Collection of Information and Recipes of all descriptions of the greatest utility to the general Sportsman, to which is added a series of Recipes on the Management of Dogs in Health and Disease. Vol. I. of "THE FIELD" LIBRARY. Third Edition. Large post 8vo., price 7s. 6d. cloth; post free, 7s. 10d.
- BY LAKE and RIVER: an Angler's Rambles in the North of England and Scotland.** By FRANCIS FRANCIS, Author of "A Book on Angling," &c. &c. Post 8vo., price 8s. 6d.; post free, 9s.
- A YEAR OF LIBERTY; or, Salmon Angling in Ireland.** By W. PEARD, M.D., LL.B. Vol. IV. of "THE FIELD" LIBRARY. Price 5s. cloth; post free, 5s. 5d.
- THE INTERNAL PARASITES of our DOMESTICATED ANIMALS;** a Manual of the Entozoa of the Ox, Sheep, Dog, Horse, Pig, and Cat. By T. SPENCER COBBOLD, M.D., F.R.S., F.L.S. Illustrated with numerous woodcuts. Post 8vo., price 5s., by post 5s. 3d.
- "WHETSTONES FOR WITS:" or Double Acrostics.** By VARIOUS HANDS. Edited by "CRACK." Price 5s.; by post, 5s. 4d.  
"You have not the book of riddles about you, have you?"—*Merry Wives.*
- THE ILLUSTRATED QUEEN ALMANAC and LADY'S CALENDAR;** comprising Work-table and other Patterns, and much Information interesting and useful to Ladies. Published annually. Price 1s.; by post, 1s. 3d.
- CHESS MATCH.—STEINITZ v. BLACKBURNE.—**The Games in the Chess Match between Messrs. Blackburne and Steinitz, annotated by STEINITZ. Reprinted, in large type, from "The Field," with additional Notes and Comments, and Diagrams of the most interesting positions. Price 1s.
- THE ANGLER'S DIARY, wherein the Angler can register his take of Fish throughout the year.** An extensive List of Fishing Stations throughout the World is added. Post 8vo., price 1s. 6d.; by post, 1s. 8d.
- THE SILKWORM BOOK; or, SILKWORMS ANCIENT and MODERN, their FOOD and MODE of MANAGEMENT.** By W. B. LORD, R.A. Illustrated. In demy 8vo., price 2s. 6d., cloth gilt; post free, 2s. 8d.
- REPORTS on SALMON LADDERS, with Original Drawings, Plans, and Sections.** By FRANCIS FRANCIS. In post 4to., price 2s. 6d.; by post, 2s. 7d.
- ACTING CHARADES FOR OLD AND YOUNG.** By ARTHUR LILLIE, Author of "The Enchanted Toasting Fork," &c. Handsomely bound in cloth, price 3s. 6d.; by post, 3s. 9d.
- THE RAIL and the ROD; or, The Tourist-Angler's Guide to Waters and Quarters.** In Parts, paper wrapper, price 1s. each; in cloth, 1s. 6d. post free, 2d. extra.  
No. 4. SOUTH-EASTERN RAILWAY.  
No. 5 } GREAT EASTERN, LONDON AND NORTH-WESTERN, MIDLAND, and  
and } GREAT NORTHERN RAILWAYS.  
No. 6 }
- THE BOOK of DINNER SERVIETTES (Fourth Edition),** which contains a new Introduction on the Decoration of Dinner Tables, and General Directions for folding the Serviettes, of which there are Twenty-one different kinds given, with Ninety-two Woodcuts illustrative of the various Folds required, and the Serviettes complete. In demy 4to., on toned paper, and in fancy cover, price 2s.; by post, 2s. 2d.

LONDON: "THE FIELD" OFFICE, 346, STRAND, W.C.





W. F. STANLEY,  
**MANUFACTURING OPTICIAN,**  
**MATHEMATICAL, DRAWING,**  
AND  
**SURVEYING INSTRUMENT MAKER.**

Contractor to *H.M.* Government, also for India and Colonies.

---

Theodolites, Sextants, Levels, Compasses,

AND EVERY DESCRIPTION OF

INSTRUMENT AND MATERIAL FOR FIELD AND OFFICE,

Of the First Quality, Highest Finish, and most Moderate Price.

Manufactured for most part by SELF-ACTING MACHINERY.

---

**MEDALS :**

International Exhibitions, 1862 and 1873.

---

**ENGINE DIVIDER TO THE TRADE.**

---

**GOODS SHIPPED WITH GREATEST CARE.**

---

Mathematical, Microscopic, Photographic, and Electrical  
Catalogues Post Free.

---

W. F. STANLEY,  
GREAT TURNSTILE, HOLBORN, W.C., LONDON.

**Steam Optical Works at South Norwood.**

**T. W. WATSON,**  
Optician,  
4, PALL MALL, (UNDER THE COLONNADE.)  
**LONDON.**

---

MANUFACTURER OF  
MATHEMATICAL, SURVEYING, OPTICAL,  
AND SCIENTIFIC INSTRUMENTS.

---

THEODOLITES.

LEVELS.

SEXTANTS.

PRISMATIC COM-  
PASSES.

CROSS STAFFS.

CHAINS and TAPES.

MATHEMATICAL  
DRAWING IN-  
STRUMENTS.

TELESCOPES.

FIELD GLASSES.

SURVEYING and TRA-  
VELLING ANEROID  
BAROMETERS.

METEOROLOGICAL  
INSTRUMENTS.

ASTRONOMICAL  
INSTRUMENTS.

&c., &c.

---

MICROSCOPES AND MICROSCOPE  
APPARATUS FOR STUDENTS, AMATEURS,  
AND PROFESSIONAL PURPOSES.



